

Airbus/WSU Wingbox Challenge (Open Category)

*Showcase your aviation heritage
Design, build, and predict the performance of the lightest, strongest, and
stiffest Wingbox possible!*

Prize money

1st Prize : \$2000

2nd Prize : \$1000

3rd prize : \$500

Deadline : February 22nd, 2019

The Challenge

Wings are a critical part of airplanes

- They carry the weight of the plane

- They are necessarily long and skinny

- The wingbox is the core structure of the wing

Engineers work very hard to make the wingbox light, strong, and stiff

Here is a chance for you to do the same, & more!

- Work with Airbus & WSU engineers

- Start your future with WSU & with Airbus

- Win prize money!

Teams

- The competition is open to the public and the team members can include hobbyists, practicing engineers, faculty, and students (high school, university, etc.).
- As part of the competition, you will be required to conduct structural analysis and predict the deflections and failure loads. You may use classical methods or numerical tools. It would be in the best interest of the teams to have at least one member who is proficient in structural analysis.

The Challenge

Using balsa sheets and sticks, **design**, **build**, and **predict** the performance of the lightest^A, strongest^B, and stiffest^C wingbox. The wingbox should withstand a minimum $P=20$ lbs. to qualify.

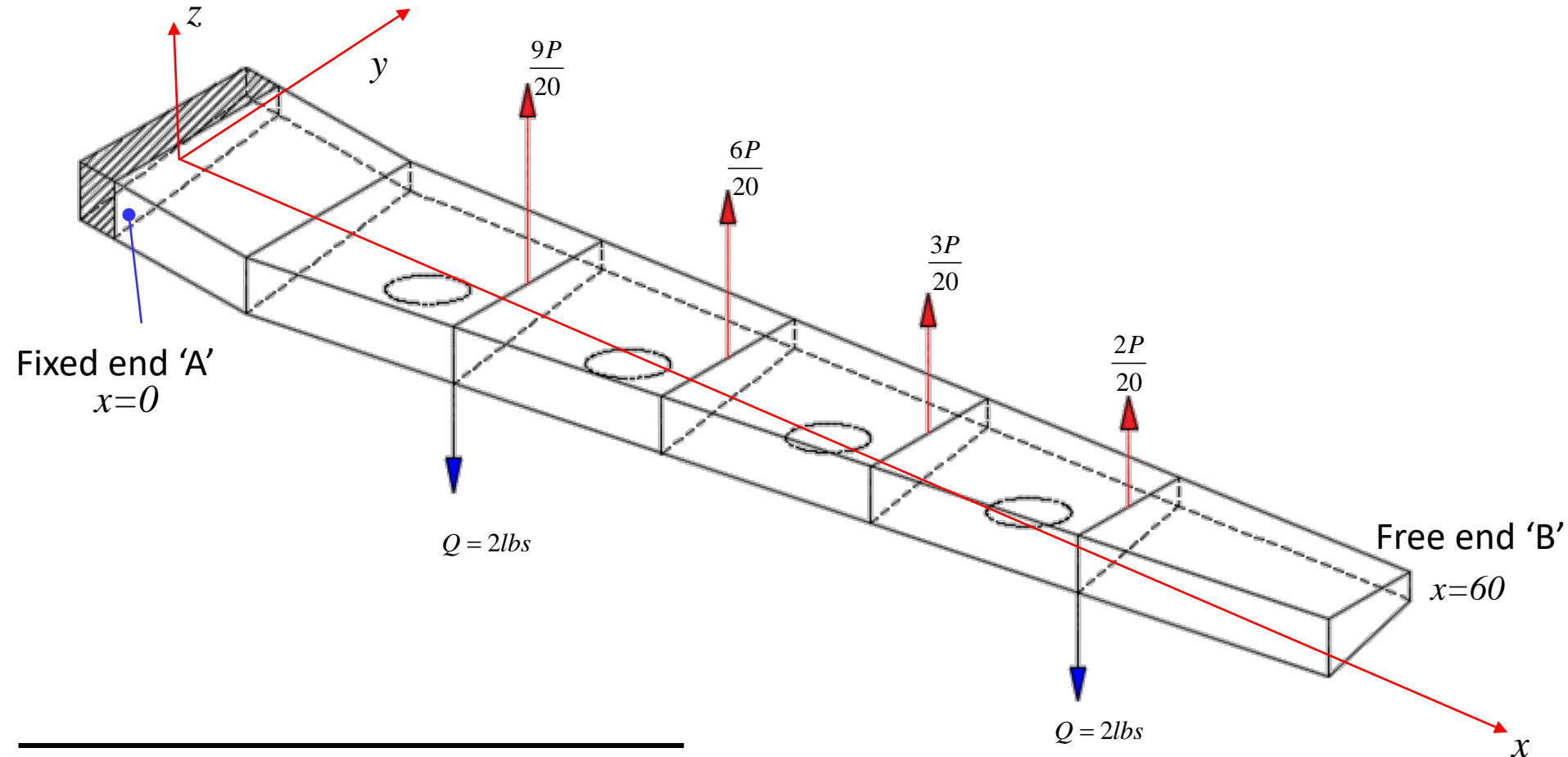

-
- A. Minimize the weight
 - B. How much force it can withstand
 - C. Higher stiffness implies smaller deflections and twist

Geometry

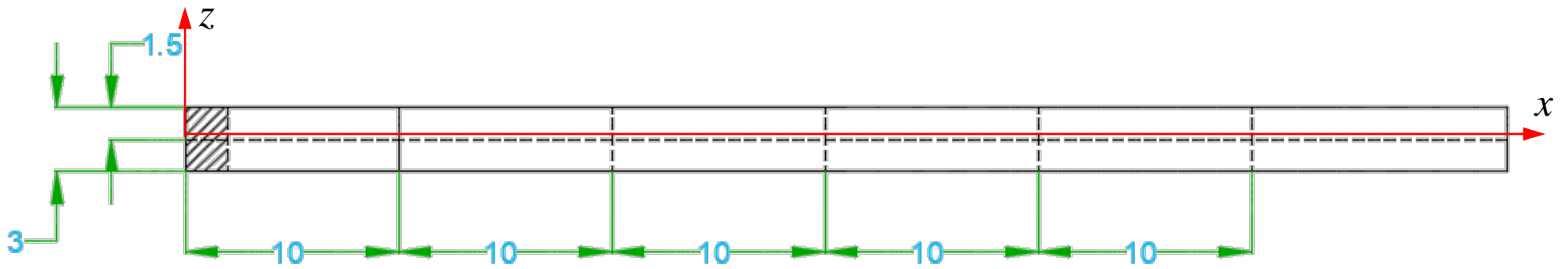
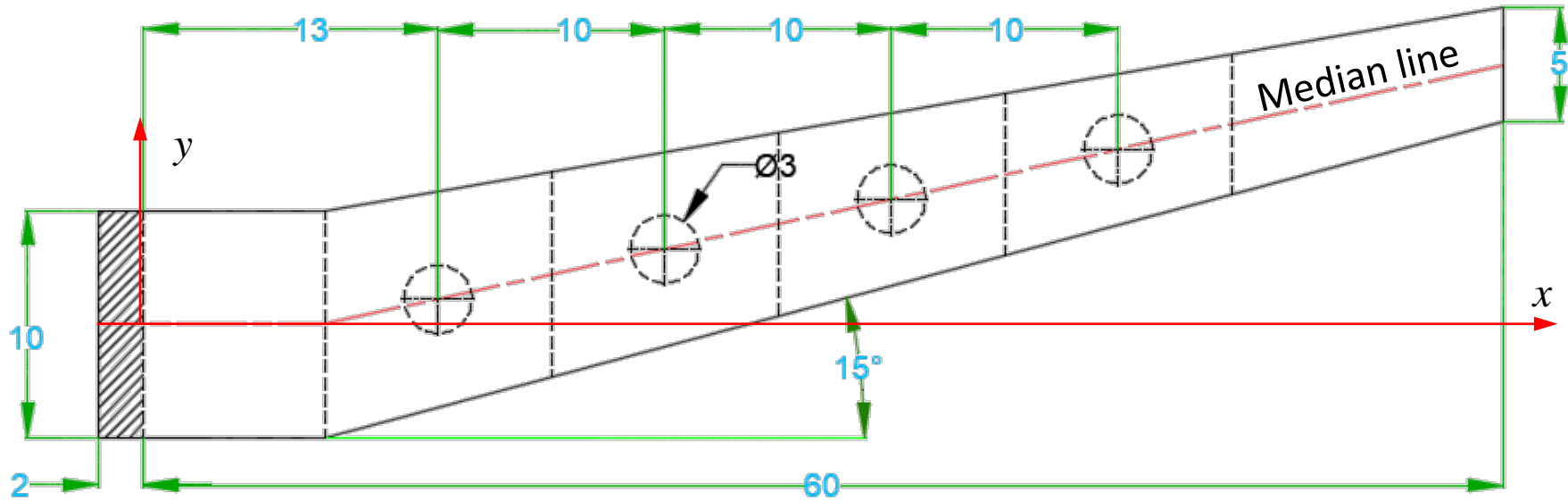

All dimensions in INCHES
Tolerances : +/- 0.1 in

Geometry: Rib Locations

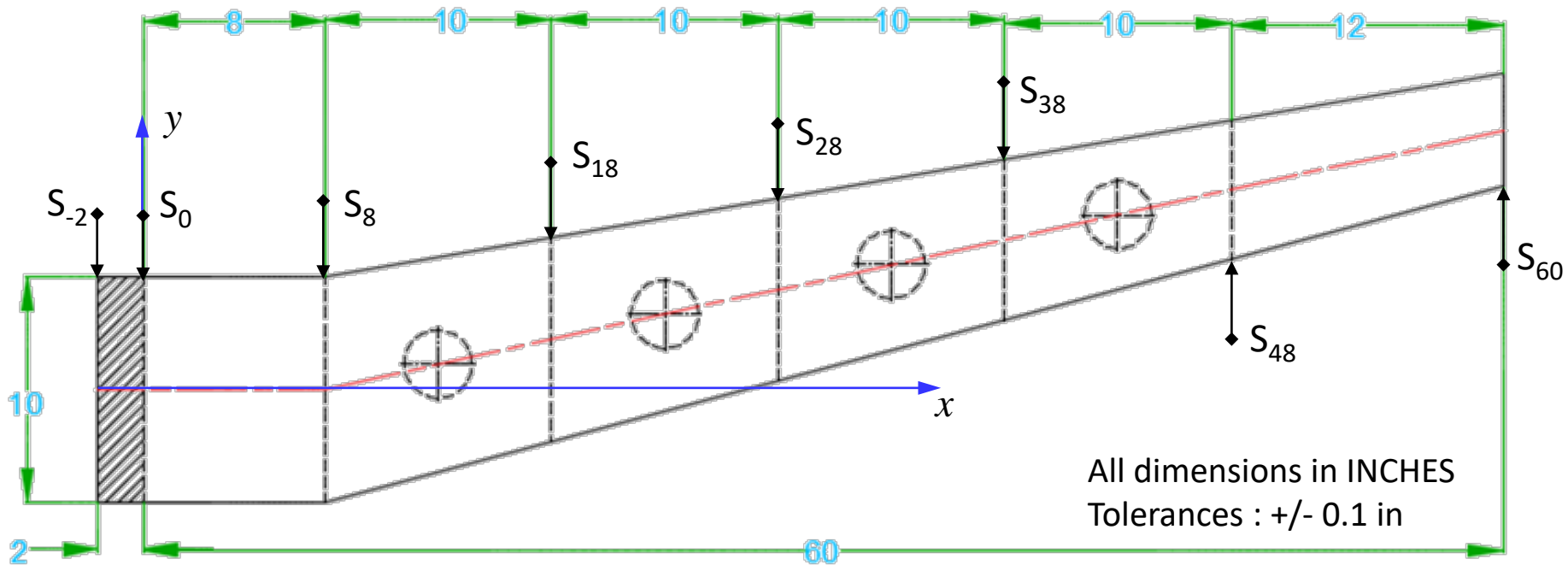

- 1/8in thick balsa ribs are mandatory at stations S_8 , S_{18} , S_{28} , S_{38} , S_{48} , and S_{60} . These ribs are required for load introduction.
- There should be 2 inches thick **rib placed** between stations S_{-2} and S_0 as illustrated by the hatched region. The hatched region will be encased (potted) in a polymeric matrix to provide end-fixity.
- The 2 inches thick rib must be bonded to the surrounding parts
- The skins, spars, stringers must extend all the way till station S_{-2} .
- Additional ribs may be placed at other locations as dictated by your design

Cross-section geometry

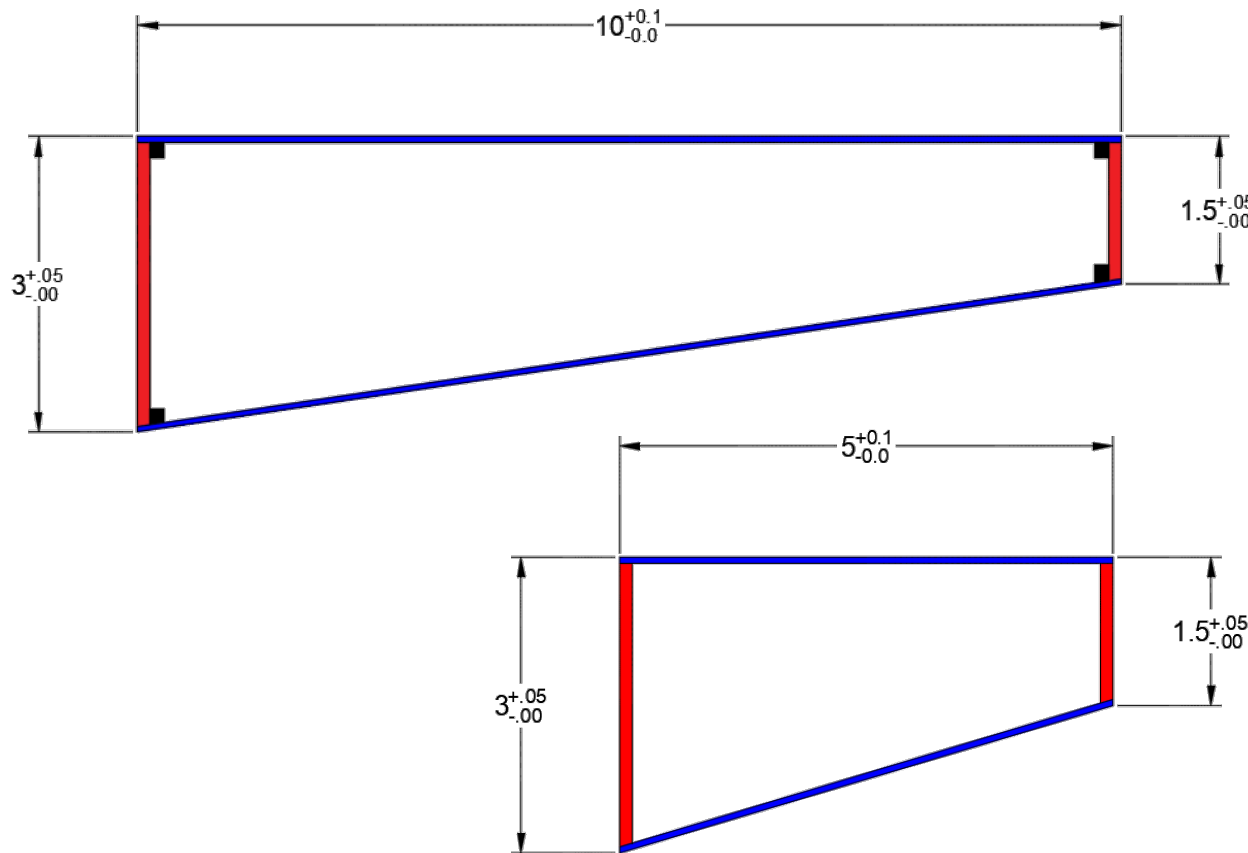

Exterior dimensions not to be exceeded between stations S_{-2} and S_8

Exterior dimensions not to be exceeded at station S_{60}

Note: The spar, skin and stiffeners shown in the figure are for illustration only.

All dimensions in INCHES

Geometry: Spar Locations

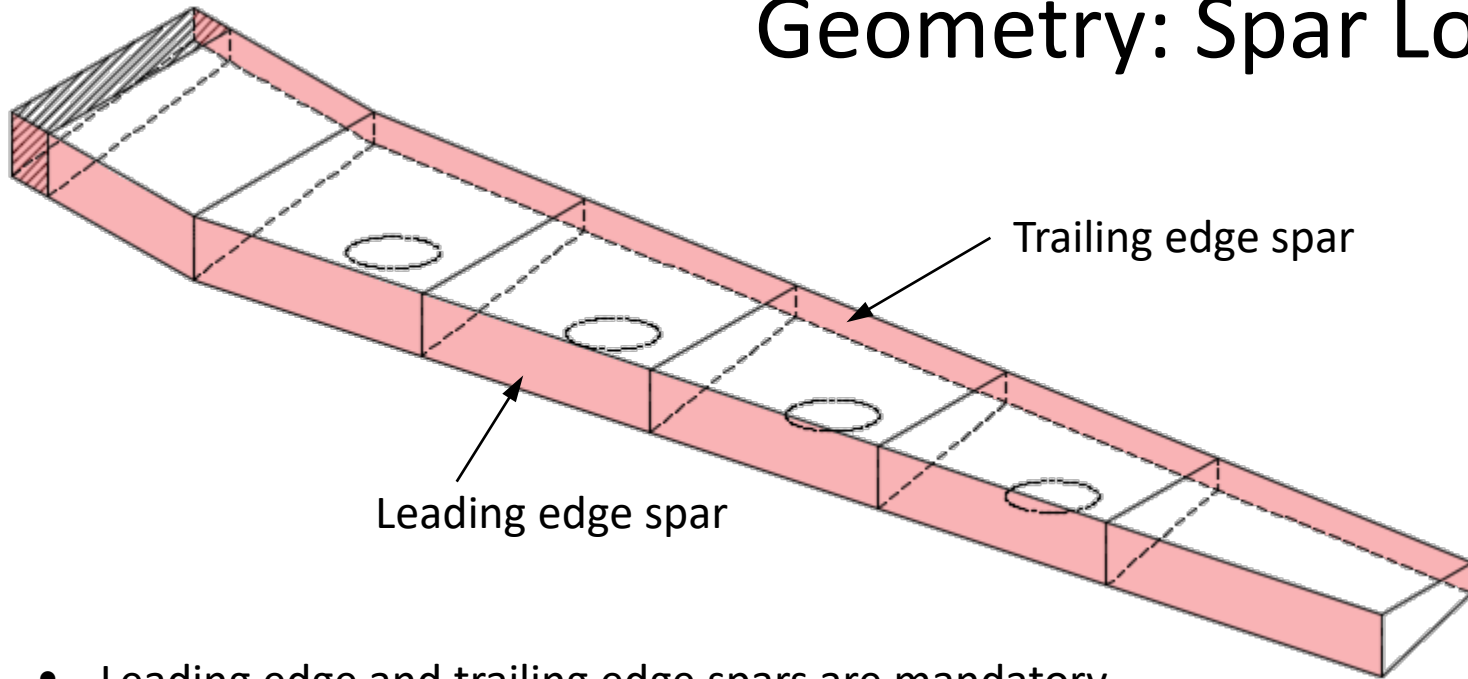

- Leading edge and trailing edge spars are mandatory.
- Additional spars may be used as necessary.
- The spars should extend to station S_{-2} to provide end-fixity.

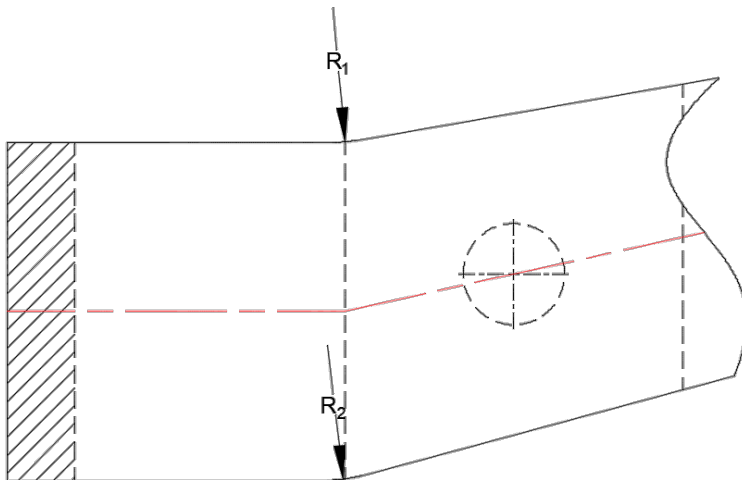

- Transition radii R_1 and R_2 not to exceed 4 inches.

Geometry: Skins

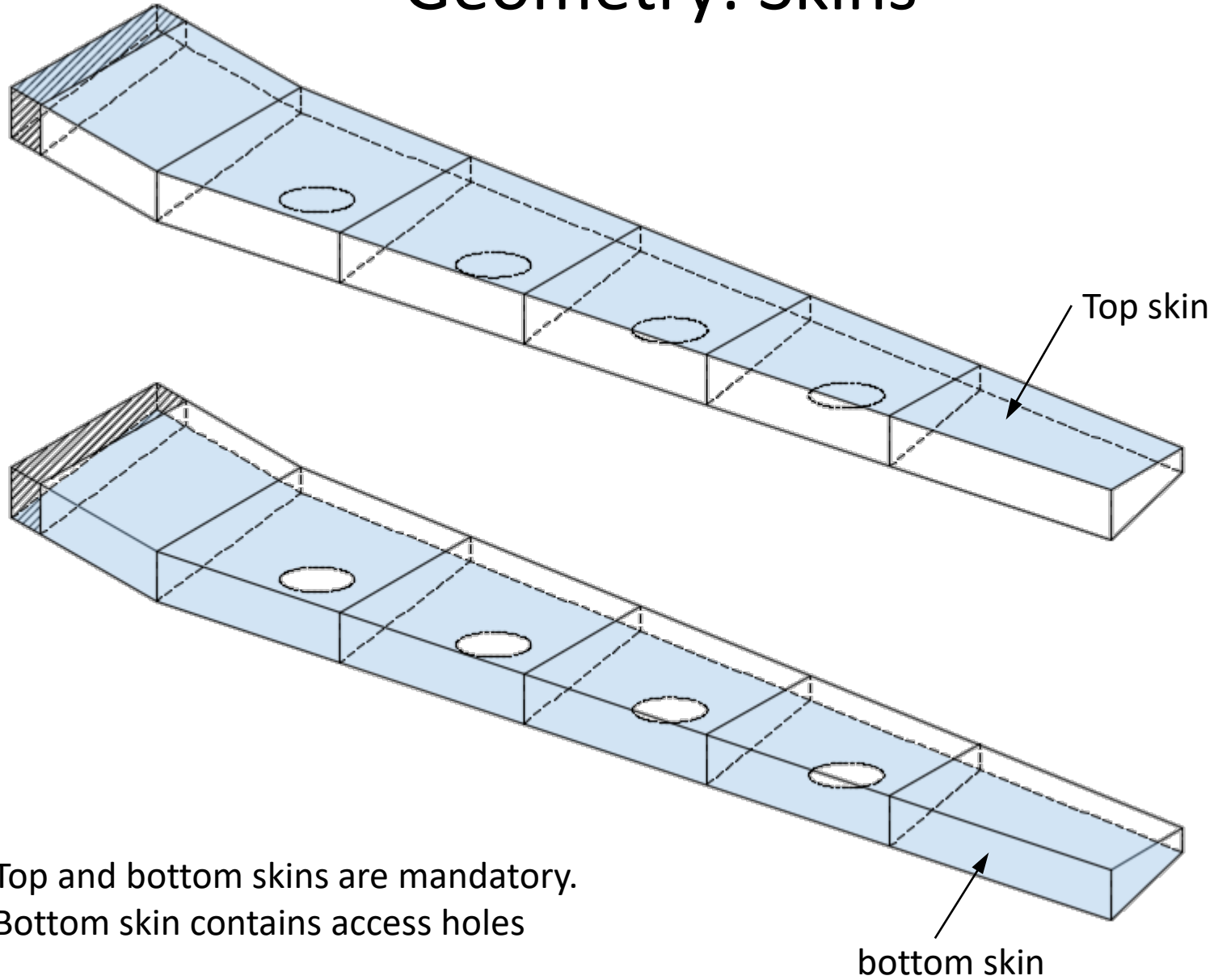

- Top and bottom skins are mandatory.
- Bottom skin contains access holes

NOTES

- 1) The balsa sticks (extending the length of the wingbox) must pass through recesses cut in the ribs as illustrated in the figure below.
- 2) You may cut lightening (weight saving) holes in the ribs.
- 3) Once you have decided on the locations and dimensions of the recesses in the ribs, you may utilize the **laser cutter** at WSU to have your ribs cut precisely.

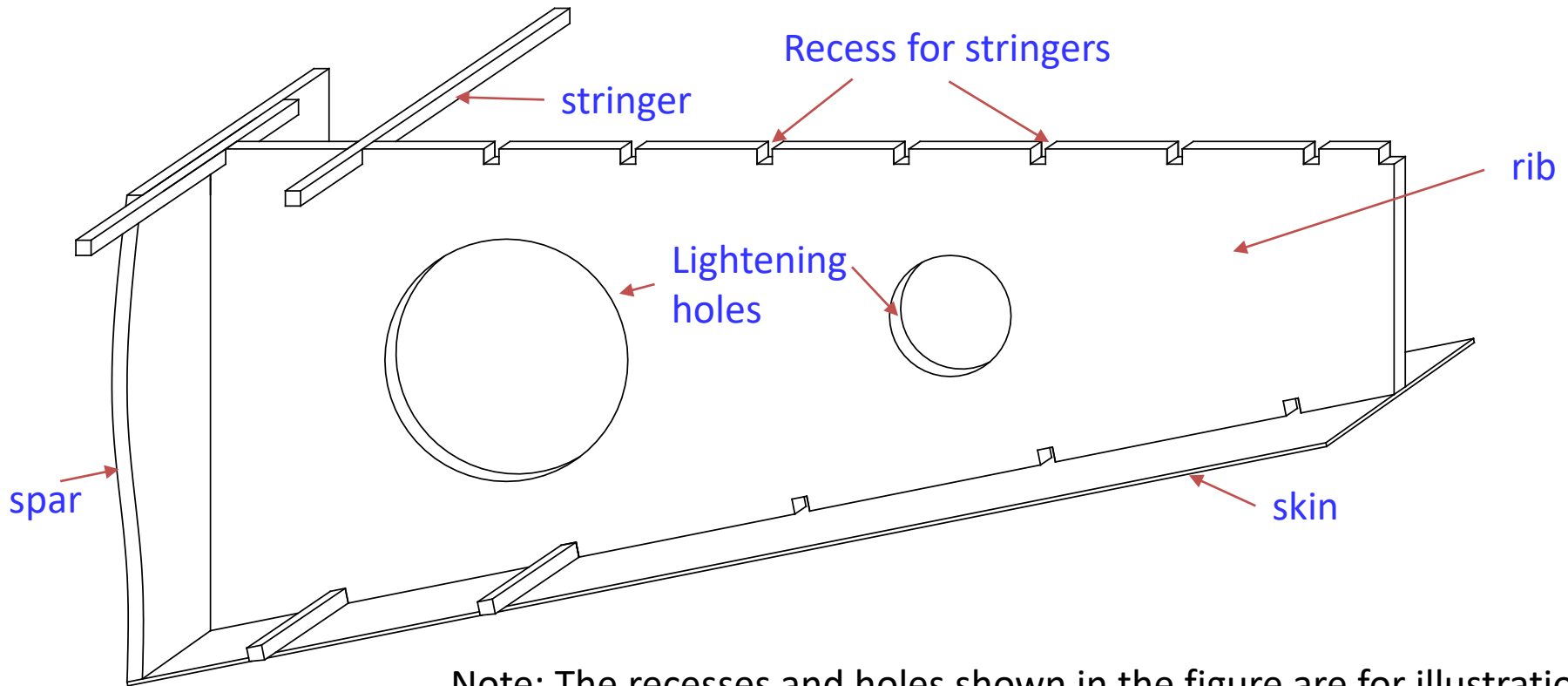

Note: The recesses and holes shown in the figure are for illustration purposes only. Their size, shape, and locations may be different for your design.

Geometry: Access ports

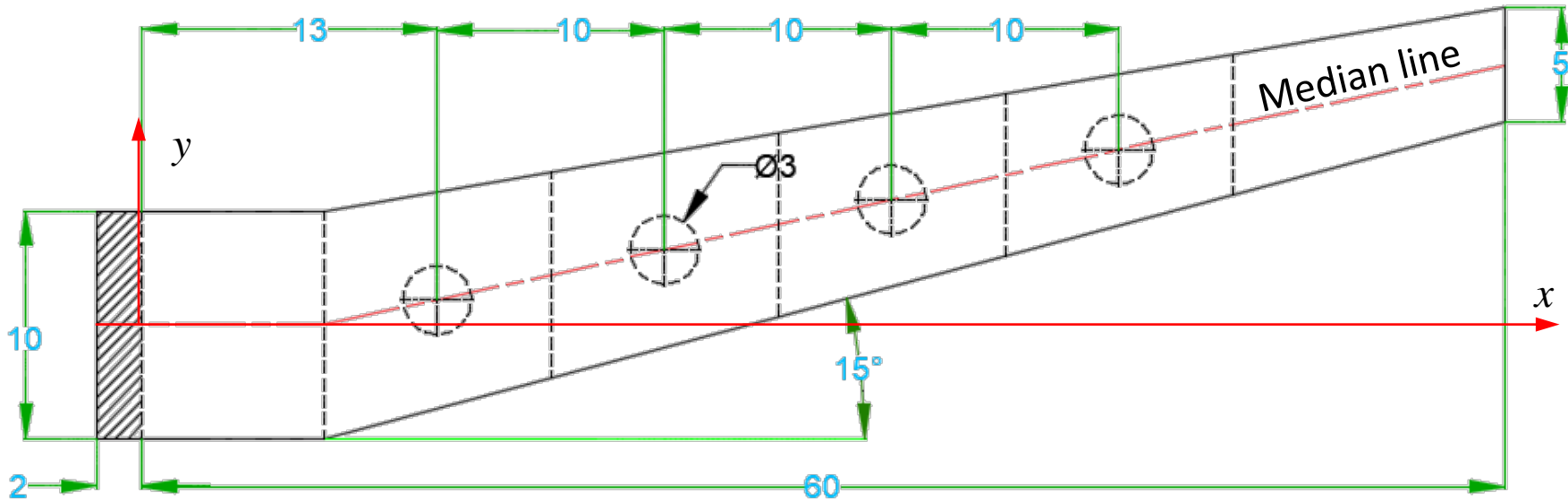

- 1) Circular access ports measuring 3 inches in diameter must be cut in the bottom skin of the wingbox at locations identified in the above drawing. The holes may be cut using the laser cutter at the WSU Experiential Engineering building.
- 2) You may reinforce the edges of the holes using balsa sheets and/or sticks. The reinforcements must be on the interior of the skin.

Materials

- The balsa skins should be no more than 1/16 inches thick.
 - You may laminate thinner sheets together as necessary
 - The skin thickness may be varied as required without exceeding the above limit
- The balsa spars should be no more than 1/8 inches thick.
 - You may laminate thinner sheets together as necessary
 - The spar thickness may be varied as required without exceeding the above limit
 - Apart from the mandatory leading edge and trailing edge spars, you may use additional spars in between.
- Balsa sticks with only 1/8-inch or 1/16-inch square cross-section dimensions are allowed. (May not be laminated)
 - The balsa sticks(stringers) must be placed on the interior of the structure.
 - Any combination of balsa sticks may be used
 - The balsa sticks may run in any direction (lengthwise, diagonal, etc)
 - The stringers can be terminated ahead of the free end if required
- The balsa ribs must be no greater than 1/8-inch thick.
- The rib at the fixed end (which will be encased in potting compound) must be 2 inches thick. You may use balsa or other wood for this rib.
- Use hobby store adhesives for bonding (Superglue, epoxy, etc.)

Loads

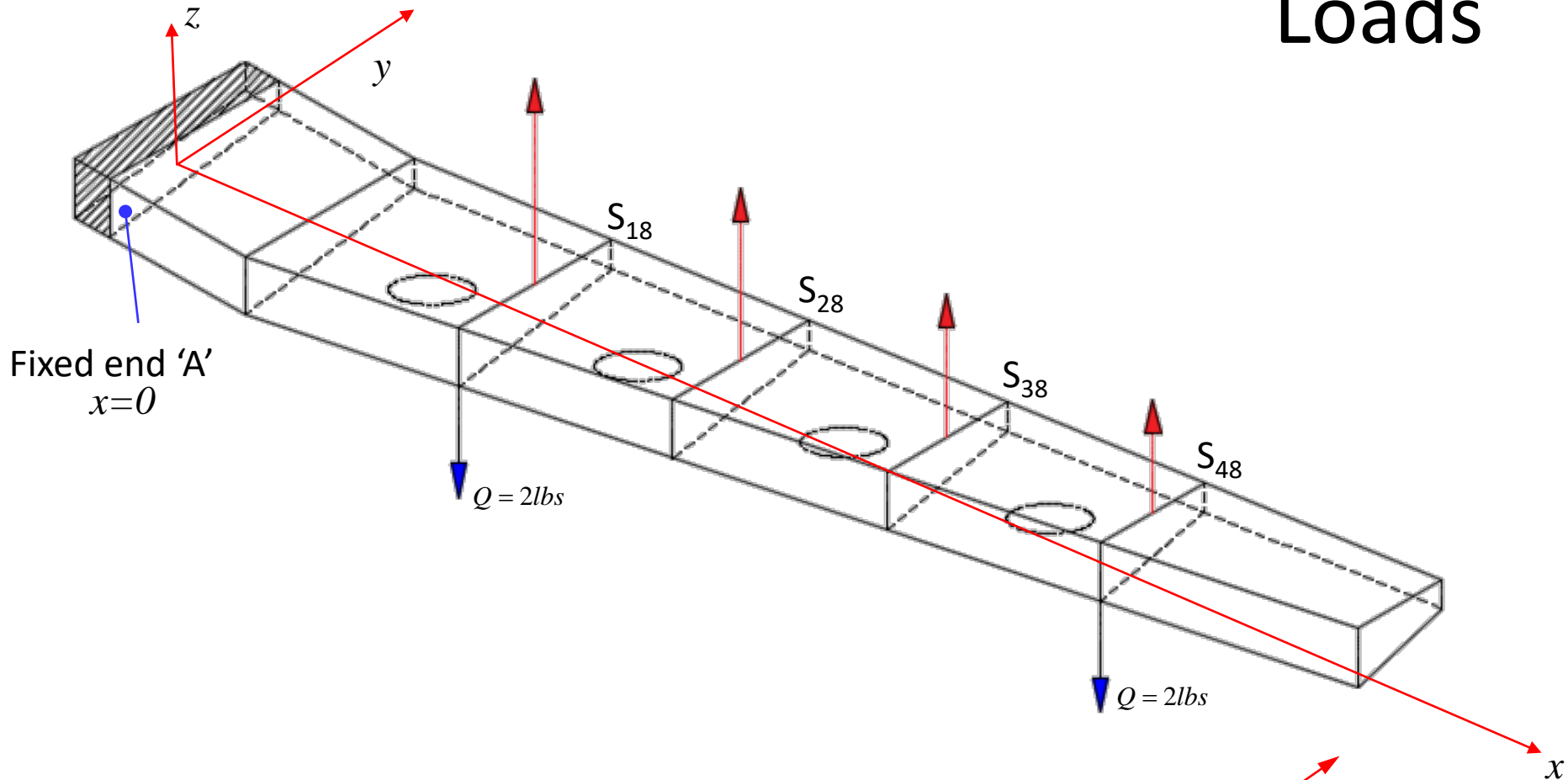

Initial loads of $Q=2lbs$ will be applied. While holding this load, the force P will be increased until failure occurs

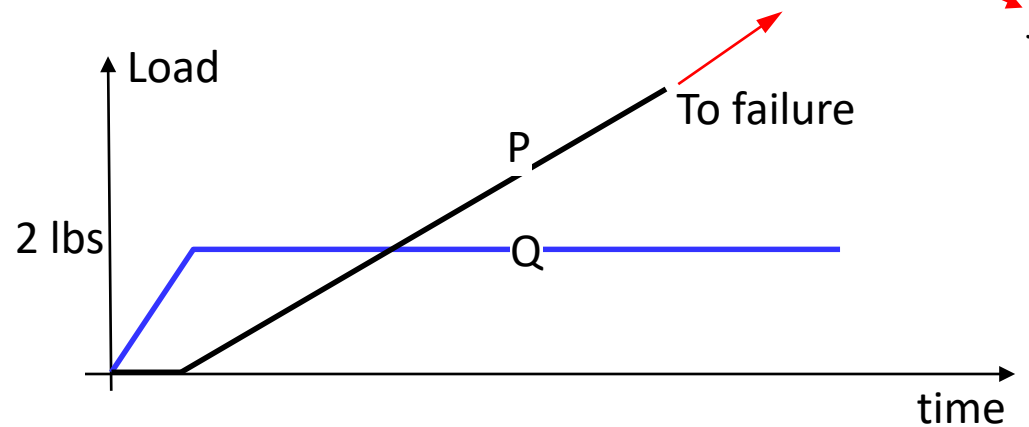

Wingbox Challenge Rubric

$$Score = S_{performance} + S_{analysis} + S_{report}$$

$$S_{performance} = 0.5 \frac{P_{max}}{W_{wing}} + 0.1 \frac{Q}{\delta_Q} + 0.05 \left[\frac{P_{20}}{\delta_{20}} + \frac{P_{20}}{\theta_{20}} \right] - 10 \frac{W_{Wing}}{1.5} - 10 \frac{W_{glue}}{W_{wing}}$$

$$S_{analysis} = 10 \left(1 - f \left(P_{max}, P_{pred}, 0.1 \right) \right) + 10 \left(1 - f \left(\delta_Q, \delta_{Q_pred}, 0.1 \right) \right) + 10 \left(1 - f \left(\delta_{20}, \delta_{20_pred}, 0.1 \right) \right)$$

$$f(A, A_{pred}, \beta) = \begin{cases} 0 & \frac{|A - A_{pred}|}{A_{pred}} \leq \beta \\ \frac{|A - A_{pred}|}{A_{pred}} - \beta & otherwise \end{cases}$$

Note : The tolerances for strength and stiffness are based on variability in material properties.

W_{glue} ~ weight of glue (lbs)

W_{WING} ~ weight of wingbox (lbs)

P_{max} ~ Measured failure load (lbs)

P_{pred} ~ predicted failure load (lbs)

P_{20} ~ P=20 lbs (+Q=2lbs)

δ_{20} ~ Measured end deflection (along load) at P=20 lbs (+Q=2lbs)

δ_{20_pred} ~ Predicted end deflection (along load) at P=20 lbs (+Q=2lbs)

δ_Q ~ Measured end deflection (along load) at Q=2 lbs

δ_{Q_pred} ~ Predicted end deflection (along load) at Q=2 lbs

δ_{max} ~ Measured end deflection at failure

θ_{max} ~ Measured end twist at failure (degrees)

Wingbox Challenge Rubric...

- W_{glue} is the weight of the glue(adhesive) used. You may weigh each of the balsa parts used before assembling them and their sum gives you the total weight of balsa wood. This should be documented in your report. Weigh the completed WingBox and use it to estimate W_{glue} . If the weight of glue is not reported, for scoring purposes, $W_{\text{glue}}=0.25 W_{\text{wing}}$ will be used.
- S_{report} : (Maximum of 50 points for the report). The report shall include,
 - Drawing with dimensions and list of parts (10 points)
 - Itemized weight of Balsa/wood parts and glue (10 points)
 - Details of analysis (eqns, FEA models, etc) (20 points)
 - Summary of activities (5 points)
 - Design philosophy (5 points)

Deliverables

- **Deadline : 5 p.m., February 22nd, 2019**
- A summary report (not exceeding 10 pages in Word format, 12pt font, single spacing, 1" margins) outlining the following:
 - Team name, affiliation, list of Team members, & mentors (1 page)
 - Summary of your design (why you decided to build the wingbox a certain way) and dimensioned drawings identifying the various parts (3 pages)
 - Summary of activities (materials used, time spent in design, constructing, testing, etc.). Photographs of activities are also welcome. (2 pages)
 - Details of Wing-box analysis, and a summary of your predictions (free end deflections and rotations, failure locations) at the following loads (5 pages)
 - With $Q=2$ lbs loads
 - With $Q=2$ lbs loads and $P= 20$ lbs
 - With $Q=2$ lbs loads and your predicted failure load
- Deliver your fully constructed Wingbox to WSU
 - The teams are responsible for delivery of the Wingboxes to the below address
**200 Wallace Hall, Department of Aerospace Engineering, Wichita State University
1845 Fairmount, Wichita, KS 67260-0042**
- The Wingboxes will be tested during the **week of May 1st , 2019.**
- The results will be announced during the first week of June, 2019.