TABLE OF CONTENTS

Introduction	1
Drafting	2
Drawing Screen	3
Pull-down Menus	4
File	4
Edit	5
View	6
Insert	7
Tools	8
Drafting Workbench	10
Views and Sheets	10
Dimensions and Annotations	11
Drawing Tools	13
Bottom Toolbars	15
Top Toolbars	16
Additional Toolbars	18
Drafting Basics	19
Starting a New Drawing	19
Creating Views from a Part	27
Front View	28
Orientation Circle	29
Projection View	35
Isometric View	38
Advanced Front View	39
Local Axis System	41
Unfolded View	42
Extracted View from 3D	44
Auxiliary View	48
Section Views and Section Cuts	50
Detail Views	59
Clipping Views	64
Broken View	65
Breakout View	67
3D Clipping	71
Configuration of Views	75
Review	82
Modifying Sheets	87
Sheet Properties	87
Page Setup	88
Inserting, Reordering and Deleting Sheets	89

Modifying Views	91
View Properties	91
View positioning	94
Locating Views	97
View Names	97
Restore Properties	98
Updating Views	101
Show/No Show	104
Callout properties	105
Callout Definition	107
Callout Recreation	109
Unbreak and Unclip	111
Reordering Views	112
Modifying Projection Plane	113
View Settings	116
Dimensioning	121
Creating Dimensions	121
Length/distance	121
Angle	129
Radius	130
Diameter	131
General dimension	132
Dimensions with Intersection points	135
Chamfer	136
Thread	138
Coordinate	139
Hole Dimension Table	140
Coordinate Dimension Table	143
Chained	145
Cumulated	146
Stacked	147
Fillet Radius Dimensions	148
Dimensions for Curves	149
Setup Parameters	154
Geometrical Dimensioning and Tolerancing	162

Modifying Dimensions	171
Top Toolbar	171
Pull Down Menu Tools, Options	172
Geometrical Tolerance	174
Properties	175
Analysis	191
Positioning	193
Re-routing Dimensions	196
Interruptions	197
Dimension Clipping	199
Update	200
Analysis Display Mode	201
Generating Dimensions	202
Annotations	215
Creating Text	215
Modifying Text	218
Top Toolbar	218
Adding a Leader	232
Orientation Link	237
Positional Link	238
Attribute link	239
Replicate Text	240
Query Object Links	241
Isolate	242
Element Positioning	243
Tables	244
Creating Symbols	252
Balloon	252
Roughness Symbol	254
Welding Symbol	256
Weld	259
Markup	260
Center lines and Axis lines	260
Area Fill	263
Modifying an Area Fill	266
Changing Boundaries	266
Properties	267
Top Toolbar	270
Graphical properties	272
Arrows	273

Assembly	275
Creating an isometric view	275
Creating a view from a scene	276
Generate balloons	278
Bill of Material	279
Other views	280
Properties of a part in an assembly	282
Overload properties	284
Cut, Copy and Paste views	287
Views of parts of an assembly	289
View Links	292
2D Geometry	295
Creating a view	295
Drawing tools	295
View plane definition	299
Multiple view projection	300
2D Components	303
Background	311
Review	319
Geometry in all viewpoints	324
Filter generated elements	324
Exporting	324
Problems	325
Problem #01	325
Problem #02	326
Problem #03	327
Problem #04	328
Problem #05	329
Problem #06	330
Problem #07	331
Problem #08	332
Problem #09	333
Problem #10	334
Problem #11	335
Problem #12	336
Problem #13	338
Problem #14	339
Problem #15	340
Problem #16	341
Problem #17	342
Problem #18	343
Problem #19	344

Appendix A	347
Mechanical Design - Drafting - General	347
Mechanical Design - Drafting - Layout	348
Mechanical Design - Drafting - View	349
Mechanical Design - Drafting - Generation	351
Mechanical Design - Drafting - Geometry	352
Mechanical Design - Drafting - Dimension	353
Mechanical Design - Drafting - Manipulators	355
Mechanical Design - Drafting - Annotation and Dress-Up	356
Mechanical Design - Drafting - Administration	357
Appendix B	359
Standards	359
ASME Y14.100-2004, Engineering Drawing Practices	359
ASME Y14.1, Decimal Inch Drawing Sheet Size and Format	359
ASME Y14.1M, Metric Drawing Sheet Size and Format	359
ASME Y14.2M-1992, Line Conventions and Lettering	359
ASME Y14.3, Multiview and Sectional View Drawings	359
ASME Y14.5M-1994, Dimensioning and Tolerancing	359
Dimensioning Rules and Check Sheet	360
Title Block	360
Views	360
Dimensions	361

Introduction

CATIA Version 5 Drafting

Upon completion of this course the student should have a full understanding of the following topics:

- Creating drawings
- Creating views
- Modifying views
- Creating detail, broken, auxiliary, and section cut views
- Dimensioning and marking up view geometry
- Creating text
- Using symbols, details, and patterns in a drawing
- Creating and modifying basic geometry
- Using folding lines and multi-view projections to create view geometry
- Creating and using backgrounds

Drafting

Currently, it is necessary for designers to create paper drawings and layouts of their parts and assemblies. This course will cover the steps necessary to create multiple view drawings and detail sheets of parts and assemblies. This will include all annotations and dimensions that are necessary to finish a completed drawing.

The drafting workbench includes a variety of icons that allow for the creation of these drawings. It is normally considered that the workflow should be from 3D to 2D. There are some tools for generating 2D geometry independent of a 3D model, but it is not a common occurrence.

You should already have a good understanding of Part Design upon starting this course. This will complete a basic cycle of events from designing your own parts and creating a multiple view drawing. The course will also show how you can create a multiple sheet drawing of an assembly, as well as the detail drawings of the individual parts. Unfortunately the industry still requires and depends heavily on paper drawings. There has been much discussion on “paper-less” environments where the end users would just pull up the design on the computer and analyze the areas of interest. In the future that may be the case but until then this is an extremely important aspect of your V5 knowledge.

At any point it will be necessary to create drawings for technical publications and handbooks. This class will also explore the options available to export pictures from CATIA to wordprocessors that then could be used to create technical documents or even web documents.

Section Views and Section Cuts

Section views and section cuts are views that show the profile of a part at a position, with the areas that contain material being filled with a pattern. If the part has a material applied to it then the pattern will display based upon that material. The difference between a section view and a section cut is that a section view will show what geometry lies beyond the cut line, whereas a section cut will only show what exists at the cut line. The cut line can be either a single line or it may have jogs in it to show a cut through the same part at different places. Also available are aligned section views and aligned section cuts. The aligned style allows there to be cut lines that are not parallel and the resulting view is shown perpendicular to the cut lines.

Open the Section Views and Cuts drawing. Make sure you open the *CATDrawing* and not the *CATPart*. You should notice that the *Front* view is active since the outline is red. You are going to want the *Top* view to be active since you are going to create a section view using the *Top* view.

Double select on the *Top* view. The frame of the *Top* view should change to red. Before you define the cut line you will want to open the Section Views and Cuts part.

Open the Section Views and Cuts part and *Tile Horizontally*. You do not have to have this part opened in order to create a section view but it will show you the cut plane in the 3D part as you define the cut line.

Select the *Offset Section View* icon.  This will allow you to define a cut line in your top view.

Select to the first location to define the beginning of your section cut as shown below.

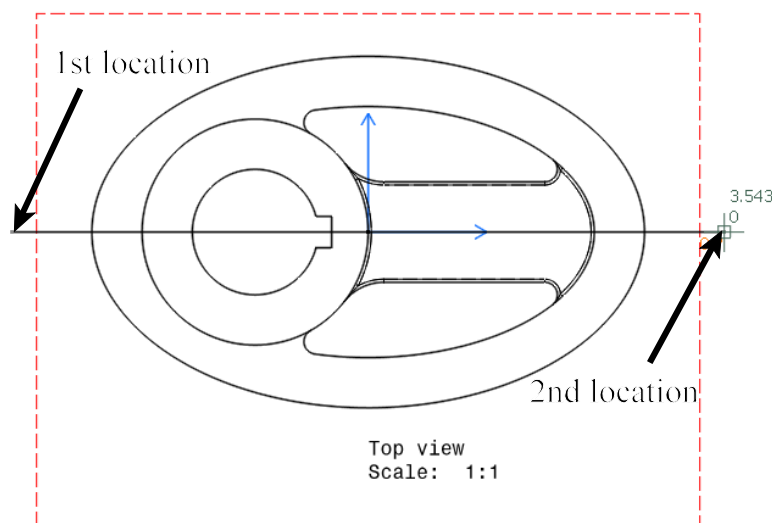

Move your mouse over to the second location as shown above but do not select the location.

You should notice the cut plane appears in the part window as you are defining the cut line. It should appear similar to the diagram shown below.

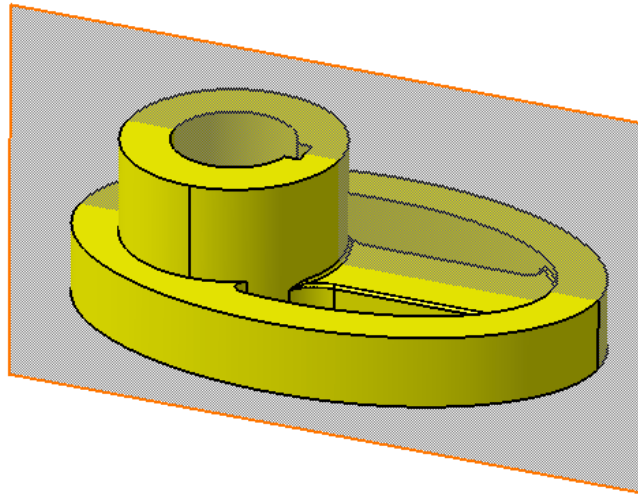

Double select at the second location. Since this is the end of your cut line you must double select. You can now position your section view.

Position the view above the *Top view* as shown below. You should notice the section arrows appear on your cut line.

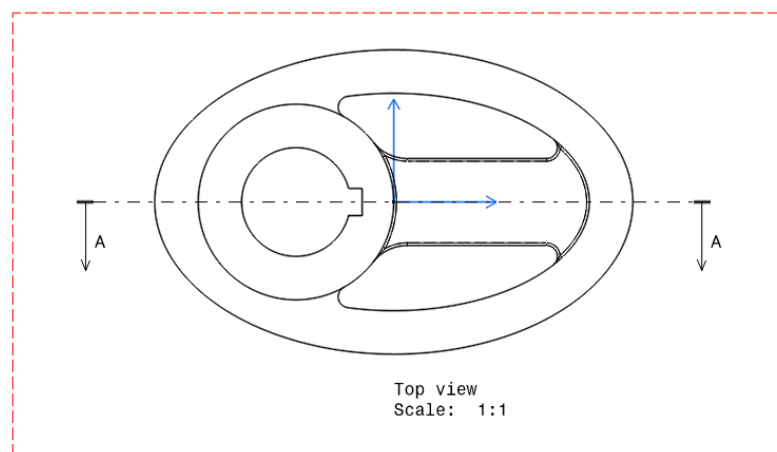
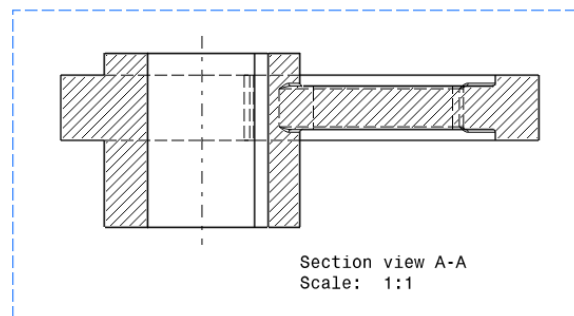

Note: You also have the option of selecting circular edges to define the cut lines. If you select on a circle it will automatically use its center point as the cut line location.

Select the **Undo** icon until the section view disappears.  You are going to create the section view using existing geometry to help locate and orientate the cut line.

In the bottom toolbar, turn on the **Create Detected Constraints** icon.  This will create any detected constraints.

Select the **Offset Section View** icon.  You will locate the cut line using a circle on the drawing.

Select the **inner circle of the cutout as shown below**. You should notice that the cut line snaps to the center of the circle but can be located at any angle.

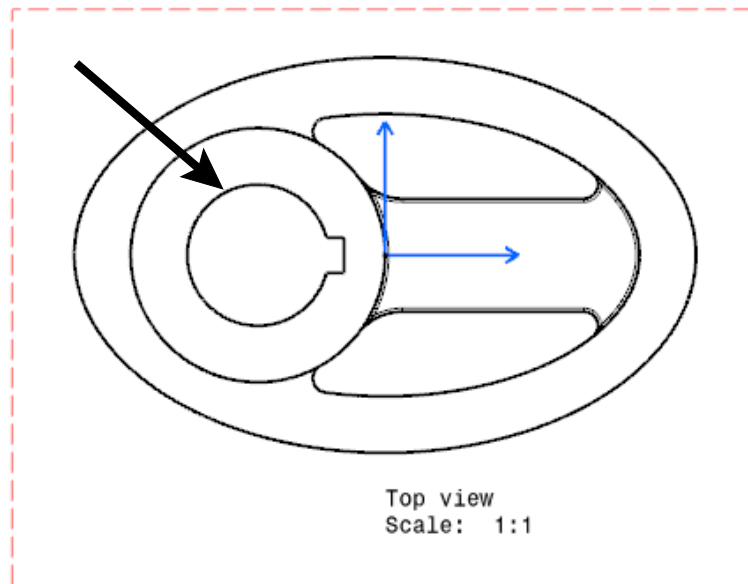

In addition, a *Tools Palette* toolbar appears with options to use existing geometry to help orientate the cut line.

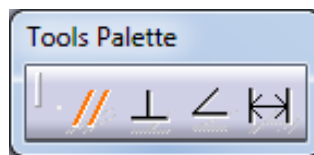

Orients parallel to the selected geometry



Orients perpendicular to the selected geometry



Orients a specific angle from the selected geometry



Orients parallel and offset from the selected geometry

Make sure the **Parallel** icon is selected and click on the top, horizontal line of the tab as shown below. // You may need to zoom in closer to select the correct geometry. The line can only be oriented parallel to the chosen line.

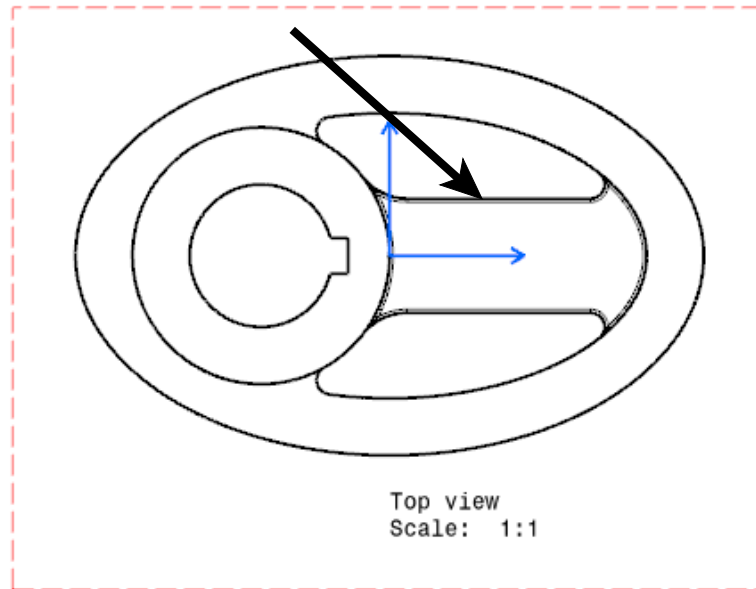



Double select to define the end of the line about at the same location as before. This defines the cut line and now you have to position the view.

Position the view above the Top view as you did earlier. By having the Create Detected Constraints icon turned on when defined the parallel to the geometry it will remain associated. You will change the angle of the tab and see how the cut line changes.

Go to the part window and go into Sketch.4 which defines the profile for Pad.3.

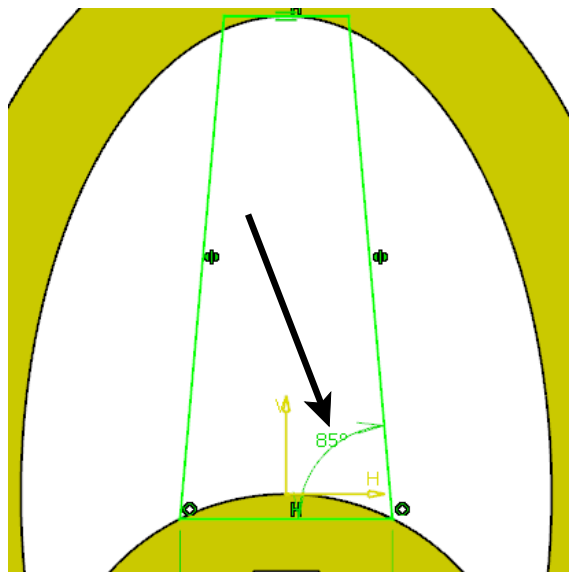
Change the 90 degree constraint to be 85 degrees and exit the sketch. This tapers the tab.



Go back to the drawing and select the **Update** icon in the bottom toolbar.  Notice that the cut line changed and so did the resulting view.

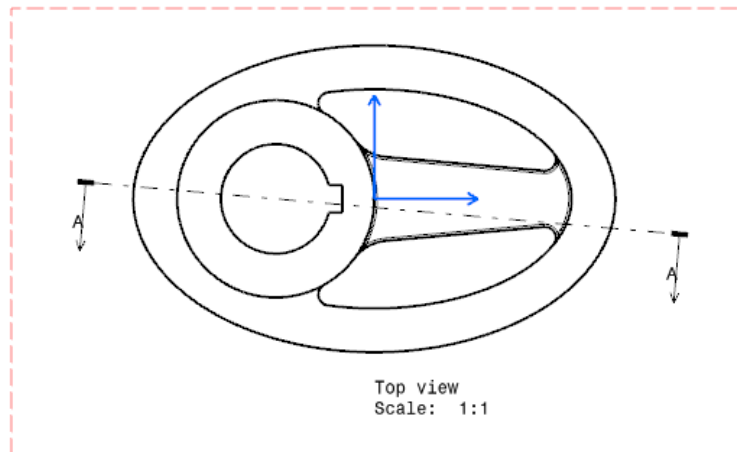
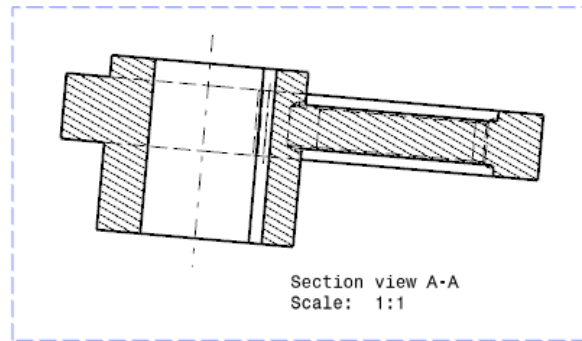

Go back to the part and change the angle back to 90 degrees inside *Sketch.4* and then return the drawing and update it. This will return the section view back to its original orientation.

Turn off the **Create Detected Constraints** icon.  It is located in the bottom toolbar.

You are now going to create a section cut.

Select the **Offset Section Cut icon**.  It is located under the **Offset Section View icon**. This will allow you to define cut lines but instead of generating a section view it will generate a section cut.

Define your cut lines as shown below. The numbers show the order of selection. Make sure you double select your last location.

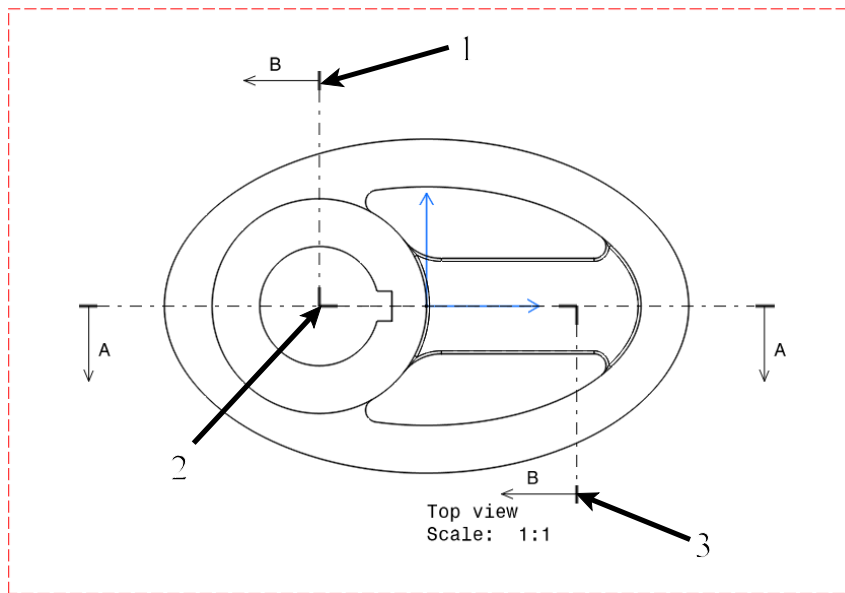

Position your view to the right of the *Top view* as shown below.

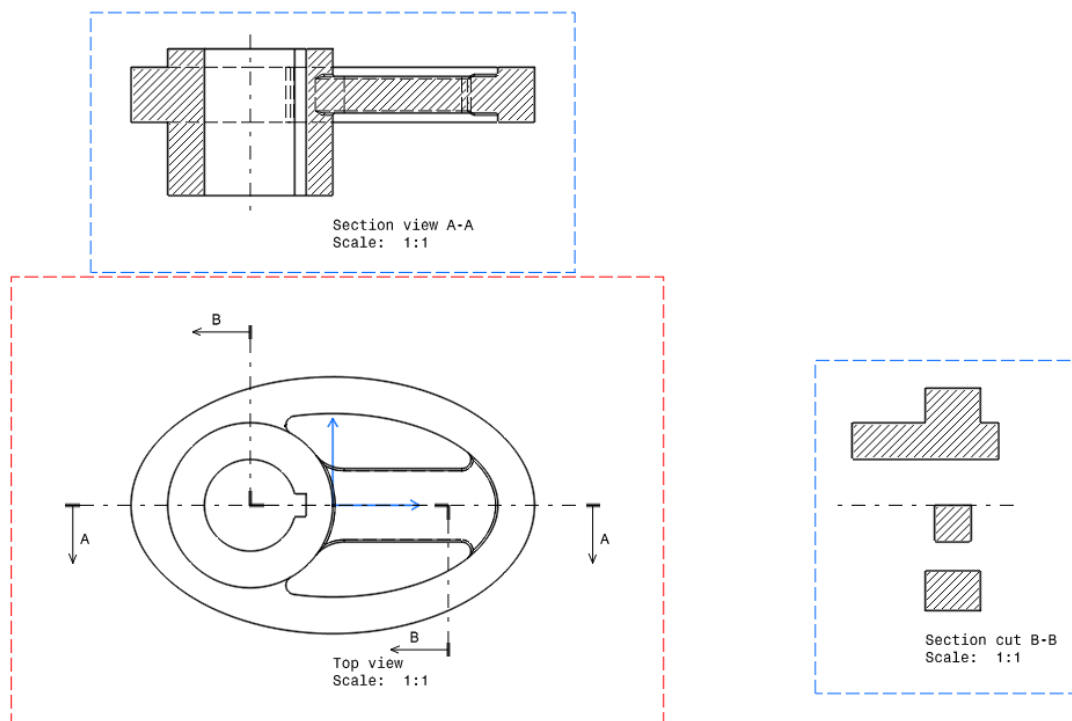

You should notice that the section cut does not show any geometry other than what the cut line actually touches. That is the difference between a section cut and a section view.

Make the Front view active. You can do this by double selecting on the *Front view*. You are going to create an aligned section view using the *Front view*.

Select the Aligned Section View icon.  It is located under the *Offset Section View* or *Offset Section Cut* icon. With this option you can create cut lines that are not parallel.

Define your cut lines as shown below. The numbers show the order of selection. Make sure you double select your last location.

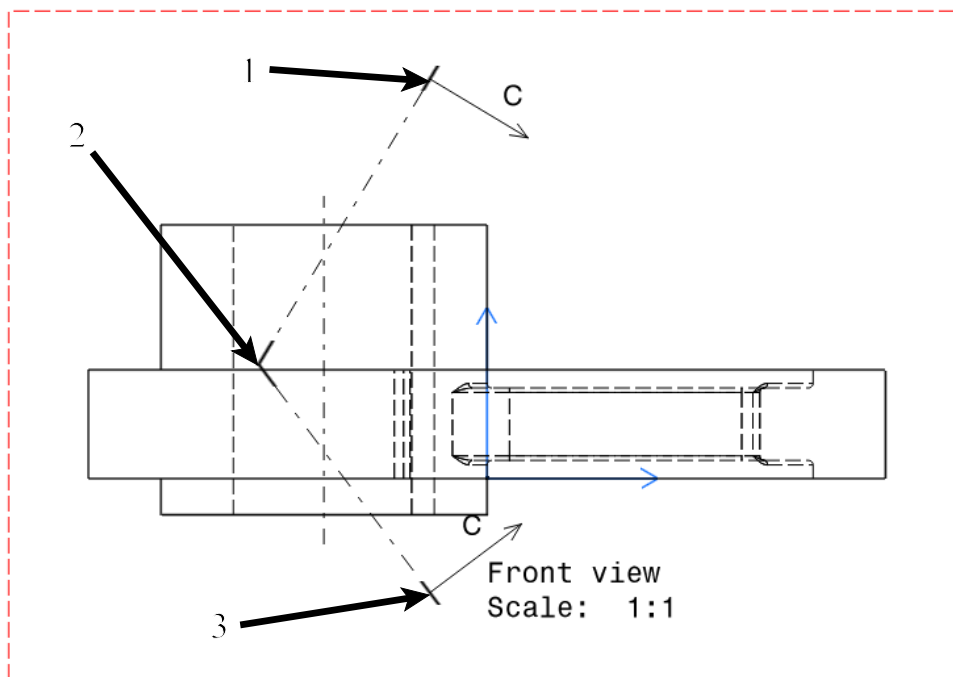

Position the view to the left of the *Front view*. The view is positioned normal to one of the cut lines.

Change the *Properties* of the aligned section view to not show *Hidden Lines*. It should appear similar to the diagram shown below.

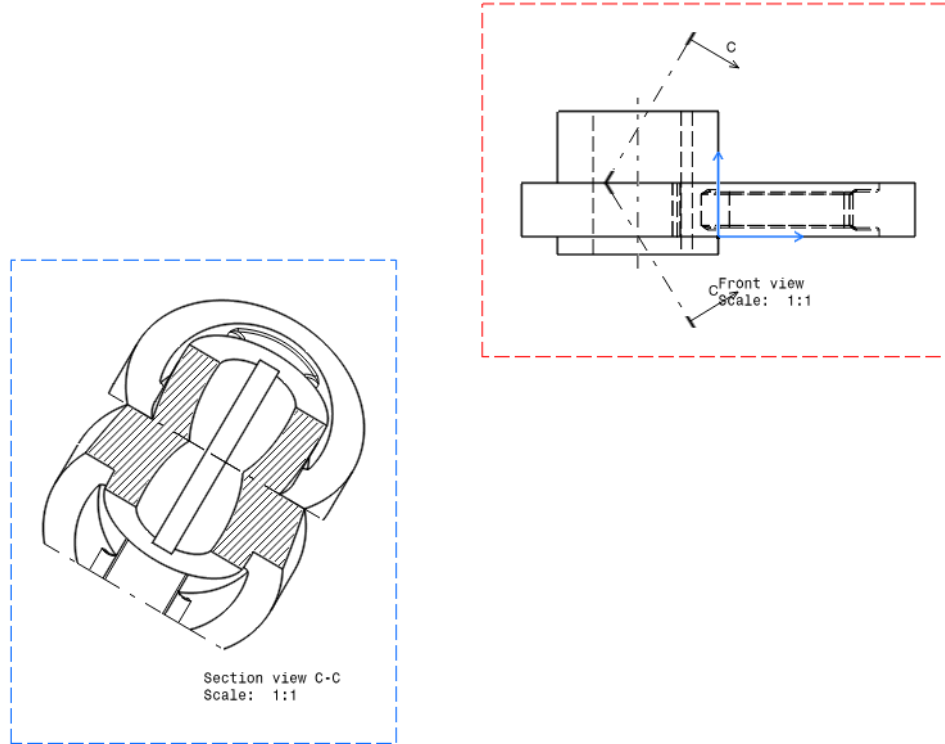

You have the option of creating aligned section views or cuts, however this exercise only shows you the option of creating an aligned section view. Creating an aligned section cut is done in the same manner except you use the **Aligned Section Cut** icon.  Feel free to try the option out on your own.

The next item that will be discussed in terms of section views and cuts is that you have the option of using a planar surface or an actual plane from your 3D part to define the cut line.

Make sure you have the part window and the drawing displayed with *Tile Horizontally*. This will enable you to see what is going on in both windows. Make sure the *Front View* is still active.

Create a plane in your part that is offset from the xy plane 0.25 inches in the positive z direction.

Go back to your drawing and select the **Offset Section View icon.**  You may have to update your views since you made a change to your part. If you do just select the **Update** icon.

Select the created plane from your part. Notice the cut line automatically appears in your *Front view*. The cut line is not associated or linked to the plane and can be modified in the drafting workbench.

Position the view under the *Front view* as shown below.

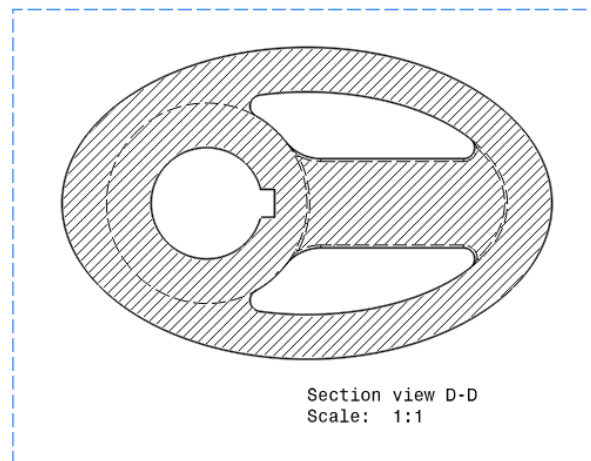
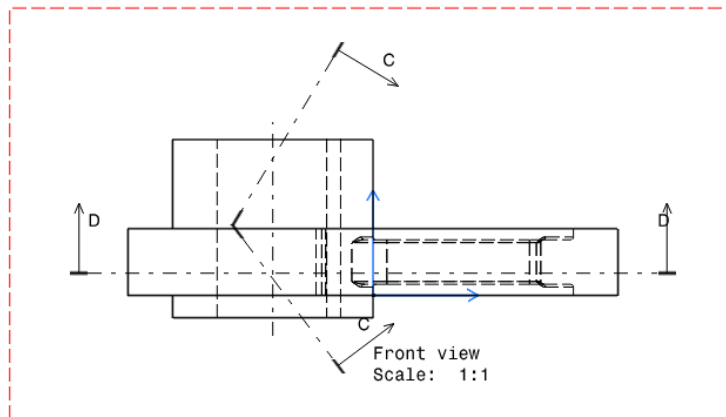

You can also create a sketch in your part that can be used to define a section line. When you use a sketch to define a section line, the section line is associated or linked to the sketch. If you want to modify the section line you would need to open the part and modify the sketch and then update your views. If you erase the sketch that was used to define the section line, then the section line would no longer be linked and it would be converted to a normal section line that could be modified within the drafting workbench.

Save your drawing and close all documents.

Dimensioning

This section will discuss the various methods of creating and generating dimensions. You will also explore the various options you have to modify the dimensions.

Creating Dimensions

Dimensioning in CATIA V5 can be a little overwhelming due to the amount of options but once you get a good understanding of the options it is fairly easy to dimension. This exercise will focus on creating the dimensions manually.

Open the Basic Dimensioning drawing. You are going to use this simple drawing to experiment creating dimensions. There are four explicit dimension options that will be covered first. These options are used explicitly to create that type of dimension.



Length/distance



Radius



Angle



Diameter

Length/distance

Select the Length/Distance Dimensions icon.  It is located under the Dimensions icon. This will allow you to create a length or a distance dimension. The *Tools Palette* window appears. These options are covered a little later and are also available by pressing the third mouse button.

In the ISOMETRIC VIEW select the line shown below. A length dimension appears. Before you position this dimension you are going to look at some of the options that you can adjust before creating the dimension.

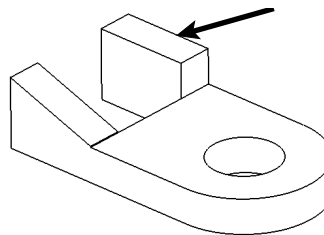

ISOMETRIC VIEW

Press the third mouse button. A menu appears similar to the one shown below. This will allow you to make some changes to how the dimension appears while you are creating it.

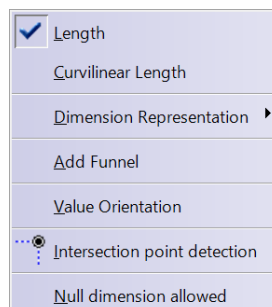

Dimension Representation These options appear as icons in the *Tools Palette* when you select certain dimension icons

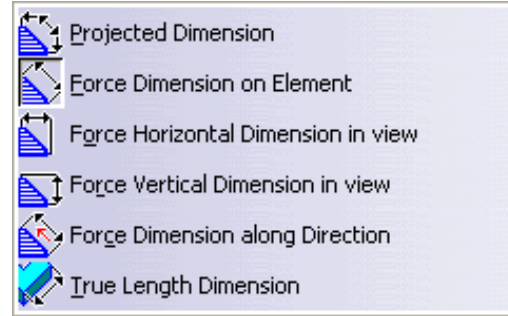
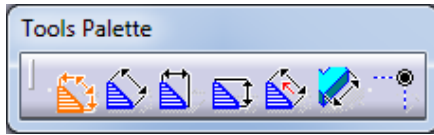

Projected Dimension

Decides the representation based upon which element you select and where you position the dimension



Force Dimension on Element

Forces the dimension to be parallel to the element

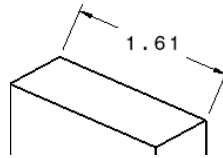

Force Horizontal Dimension

Forces the dimension to be horizontal, if not possible then it will be parallel to the element

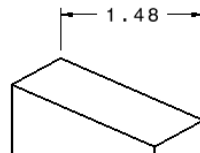

Force Vertical Dimension

Forces the dimension to be vertical, if not possible then it will be parallel to the element

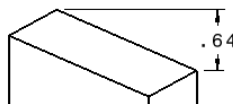



Force Dimension along Direction

Forces the dimension to measure along a specified direction. You can define the direction and have it measure along the direction, normal to the direction or along a fixed angle with respect to the view. The sub-icons that appear in the *Tools Palette* are shown below. You can access these options by pressing the third mouse button again after choosing the *Force Dimension along Direction* option.

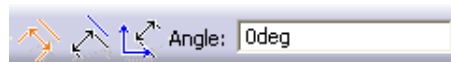

Along a specified direction or at a fixed angle with respect to the direction



Normal to a specified direction



Fixed angle with respect to the view



True Length Dimension

Gives the true length of the element, the true length option generates a purple dimension to distinguish itself as a true length

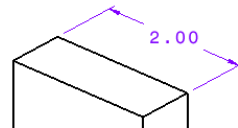

Measures from an intersection point

This option needs to be selected before defining the element to dimension in order to select intersection points of elements. This is not part of the *Dimension Representation*.

Add Funnel

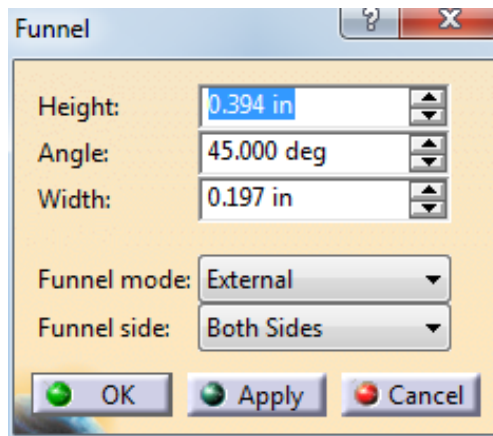

Height, Angle and Width Refers to the height, width and angle of the funnel

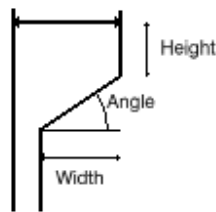

Funnel mode Determines whether the funnel will go out External or go in Internal

Funnel side Determines whether the funnel affects Both Sides, just the Left or Bottom, or just the Right or Top

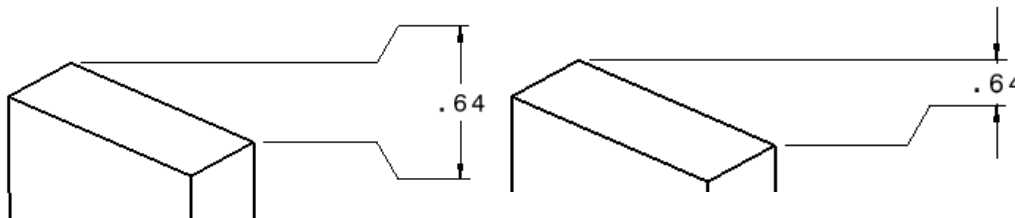

External, Both Sides

Internal, Left or Bottom

Value Orientation

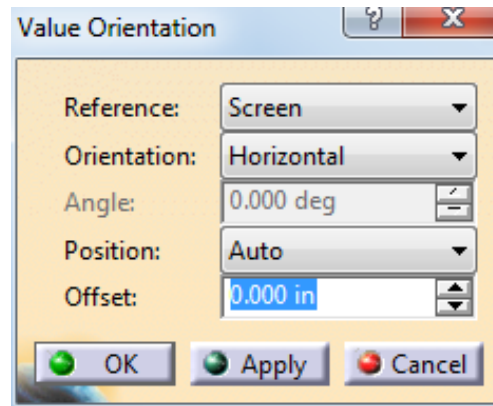

- Reference* The orientation of the value can reference the *Screen*, *View* or *Dimension Line*
- Orientation* It can be oriented *Horizontal*, *Vertical*, or *Fixed Angle* when referencing the *Screen* or *View*. It can be oriented *Parallel*, *Perpendicular*, or *Fixed Angle* when referencing the *Dimension Line*
- Angle* This option is only available if you are defining a *Fixed Angle*
- Position* Positions the dimension value either *Inside* the extremities or *Outside* the extremities. It defaults to *Auto*, which will switch the dimension value based on the room available between the extremities
- Offset* The value will be positioned this distance away from the dimension line

Select *Dimension Representation, True Length Dimension*. This will create a dimension representing the true length of the element.

Press the third mouse button again and choose *Add Funnel*. You are going to create a funnel for this dimension. The *Funnel* window appears.

Enter the following parameters: *Height = 0.5, Angle = 30, Width = 0.25, Funnel mode = External, and Funnel side = Both Sides*. This will define the funnel.

Select *OK*. The funnel is generated.

Press the third mouse button again. Notice that the *Add Funnel* option is not there, instead there is an *Edit Funnel* and a *Remove Funnel* option.

Select the *Value Orientation* option. The *Value Orientation* window appears.

Enter the following parameters: *Reference = Dimension Line* and *Orientation = Parallel* and select *OK*. The orientation of your dimension value changes.

Position the dimension up and to the right of the line and select at that location. The dimension is created. It should appear similar to the one shown below. The dimension will appear purple if you have the analysis display mode on because it is a true dimension. The following icon would be highlighted.

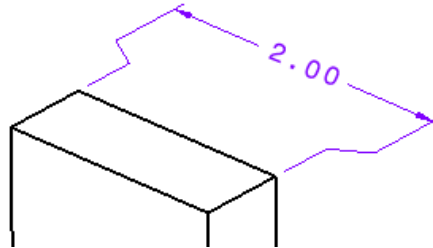

Select the Length/Distance Dimension icon again.  This is the same icon you just used.

Select the circle and the horizontal line above the circle in the *TOP VIEW* as shown below. A distance dimension appears.

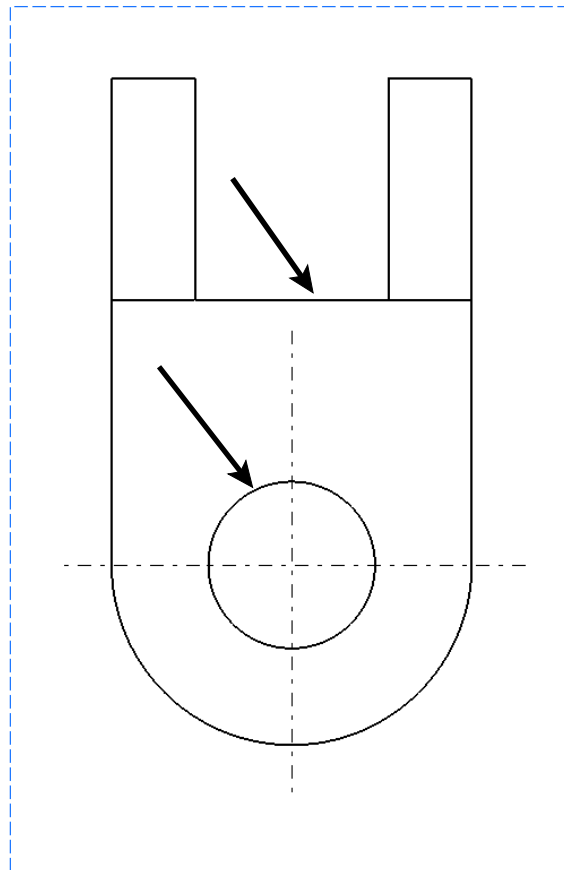

Press the third mouse button. Two new options appear. Only one will be discussed at this moment.

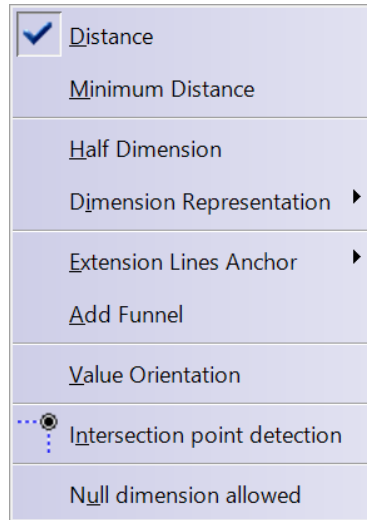

Extension Lines Anchor Determines where the extension lines will be based.

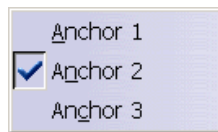

Anchor 1 Is some location along the circle

Anchor 2 This is always the center of the circle

Anchor 3 Is some location along the circle



These options would appear if you had selected two circles. You would have to choose an anchor for each extension line.

Select ***Extension Lines Anchor, Anchor 3***. In this case it uses a location on the circle which is closest to the line.

Specify the location of the dimension as shown below.

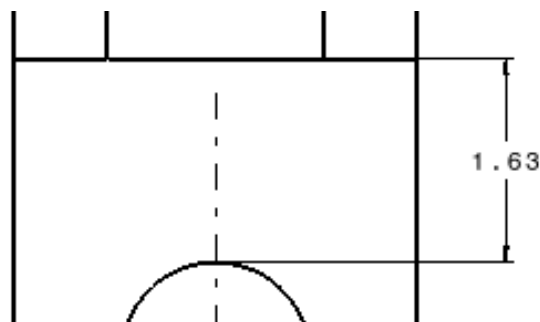

Select the **Length/Distance Dimension** icon again.



Select the **vertical center line and the leftmost vertical line of the *TOP VIEW***. You are going to create a half dimension which will automatically double the value and get rid of the extension line at the center line.

Press the **third mouse button**. This time you are going to choose the *Half dimension* option.

Select the ***Half dimension* option**. This is a toggle, therefore any dimensions that you create after this will also be half dimensions until you toggle the option back off.

Specify a location for the dimension. Notice that the value doubled in value and there is only one extension line. You are now going to undo the dimension.

Select the **Undo** icon in the bottom toolbar until the dimension disappears.



Delete the other dimensions. You can delete them by selecting them and pressing the Delete key.

Angle

Select the **Angle Dimensions icon**.  It is located under the Dimensions or Length/Distance Dimensions icon. This will create an angle dimension.

Select on the angled line and the top horizontal line in the **RIGHT VIEW**. Unless you have already turned the *Half dimension* off you need to do so now.

Press the third mouse button and select **Half dimension**. This will toggle the *Half dimension* option off.

Press the third mouse button again. Most of these options have already been covered.

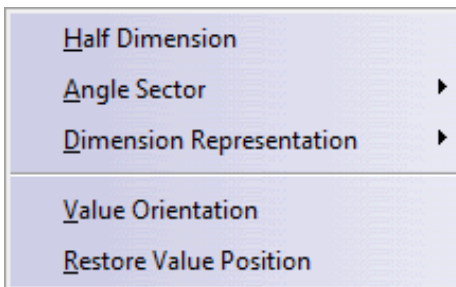

Angle Sector Allows you to specify what sector you would like to dimension



Select **Angle Sector, Sector 2**. The sectors are determined by which element you select first.

Specify the location of the dimension as shown below.

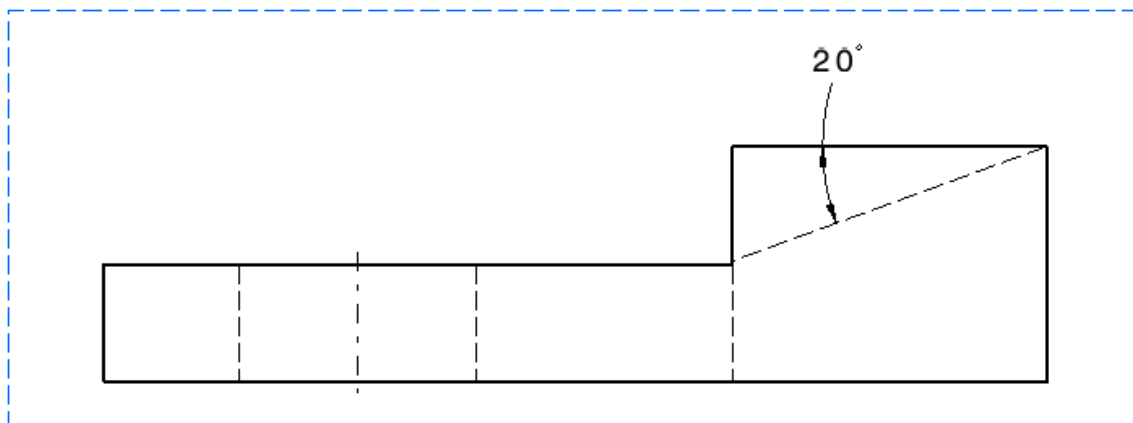

Radius

Select the **Radius Dimensions icon**.  It is located under the Dimensions or Angle Dimensions icon. This will allow you to create a radius dimension usually used for partial circles.

Select the large partial circle in the **TOP VIEW**.

Press the third mouse button. The following options appear. The *Extend To Center* option allows you to have your dimension line extend to the center point of the circle. *Note: This option is automatically activated sometimes, especially if you have the dimension located within the circle, you need to move the dimension outside the circle and then activate the option.*

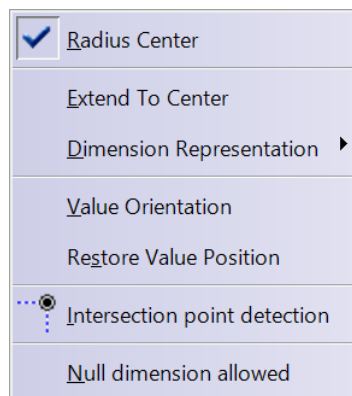

Select **Extend To Center** to extend the dimension line to the center of the circle. The dimension line goes all the way to the center point of the circle.

Specify the location of the dimension as shown below.

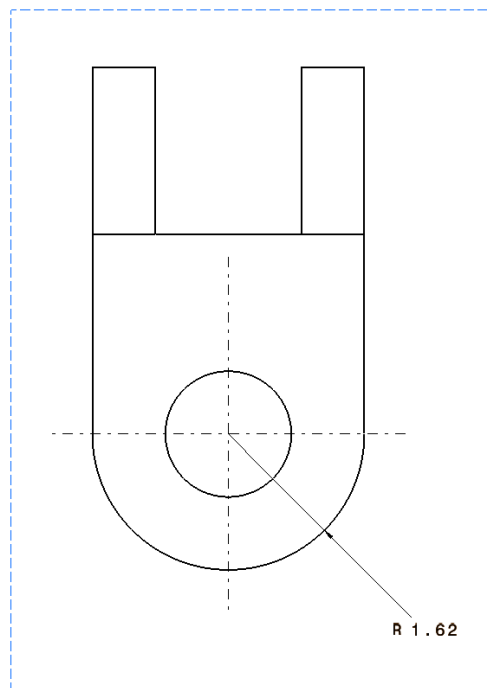

Diameter

Select the **Diameter Dimensions icon**.  It is located under the Dimensions or Radius Dimensions icon. This will allow you to create a diameter dimension usually used for complete circles.

Select the full circle in the **TOP VIEW**.

Press the third mouse button. The following options appear. The *1 Symbol* option allows your dimension to have only one arrow instead of two.

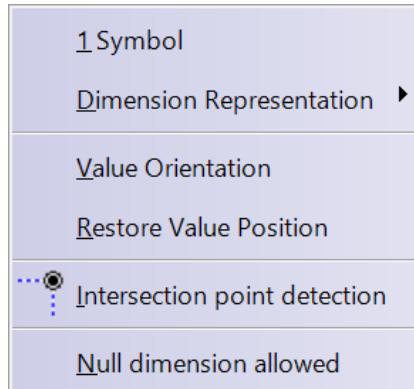

Select *1 Symbol*. The dimension line changes to have only one arrow.

Specify the location of the dimension as shown below.

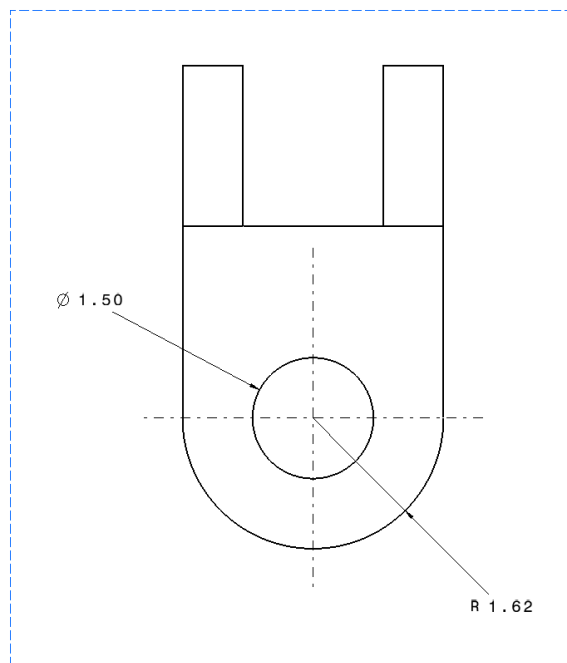

Delete all of your dimensions. You are now going to create all the necessary dimensions for this part using a single icon.

General dimension

The Dimensions icon can be used to create all four of the preceding dimensions without having to switch icons. CATIA will automatically determine what type of dimension you want to create based upon the elements that you select. You have the option of overriding its choice using the third mouse button. All the options that were discussed earlier are still available if you use the third mouse button.

Select the Dimensions icon.  It is located under the Diameter Dimensions icon. It is very similar to the Length/Distance Dimension icon. This one will allow you to create a variety of dimensions.

In the *TOP VIEW* select the top left horizontal line and the horizontal line that is below it. Refer to the diagram below if you need help.

Specify the location of the dimension as shown below.

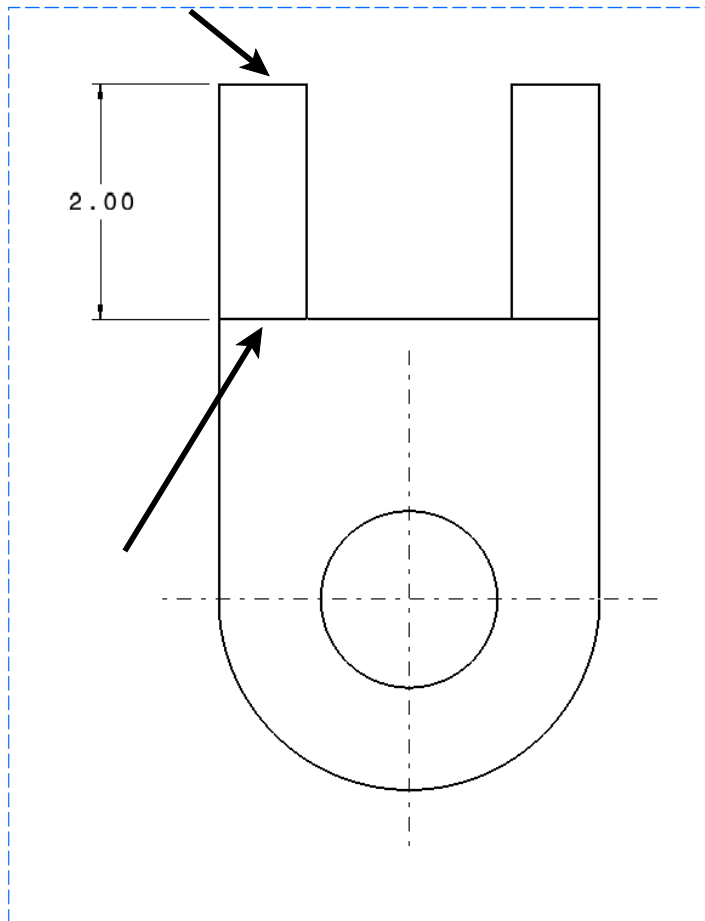

Double-select the Dimensions icon.  You can double-select the icon and it will stay active until you select the icon again.

In the *TOP VIEW* select the top left horizontal line and locate the dimension up and to the right of the horizontal line.

In the *TOP VIEW* select the large partial circle. It should show a radius dimension.

Press the third mouse button. You have the option of specifying a radius or a diameter.

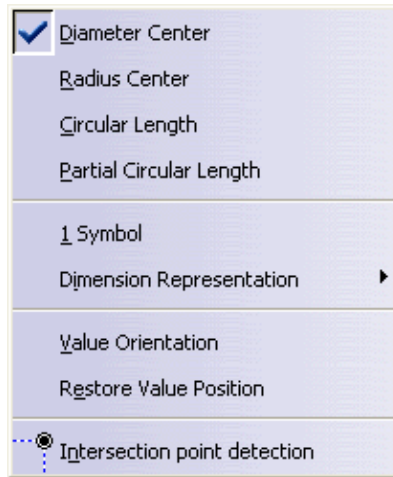

Select the *Radius Center* option and locate the dimension down and to the right.

In the *TOP VIEW* select the full circle. You want this dimension to be a diameter.

Press the third mouse button and select the *Diameter Center* option then locate the dimension down and to the left. You are finished with the *TOP VIEW*. It should appear similar to the diagram shown below.

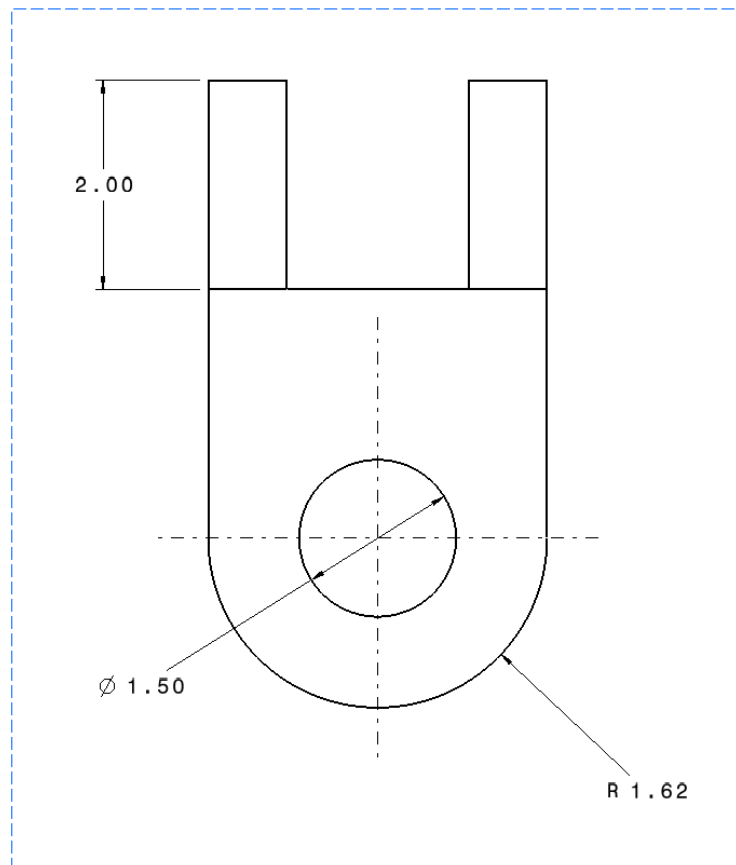

In the **RIGHT VIEW** select the leftmost vertical line. Make sure that it appears as a length and not as a diameter dimension. It may appear as a diameter because it knows that the line represents a curved surface and it defaults to *Diameter Cylinder*.

Press the third mouse button and be sure that **Length** is selected. This will switch the dimension to a length.

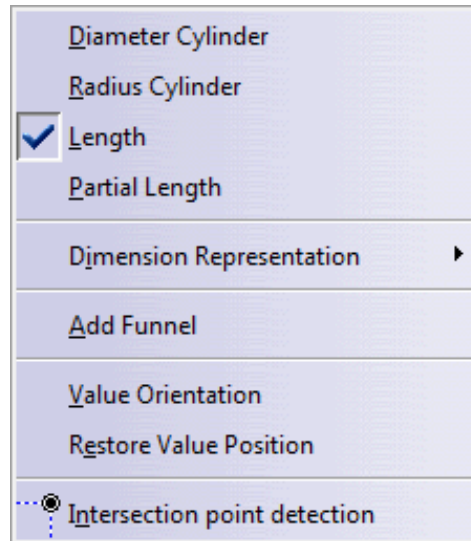

Locate the dimension to the left of the line.

Select the leftmost and the rightmost vertical line and locate the dimension above the part.

Select the rightmost vertical line and locate the dimension to the right of the line.

Select the angled line and the top horizontal line and locate the angle dimension above the horizontal line. You might have to press the third mouse button and select *Angle* in order to get the angle dimension. That finishes your **RIGHT VIEW**. It should look similar to the diagram shown below.

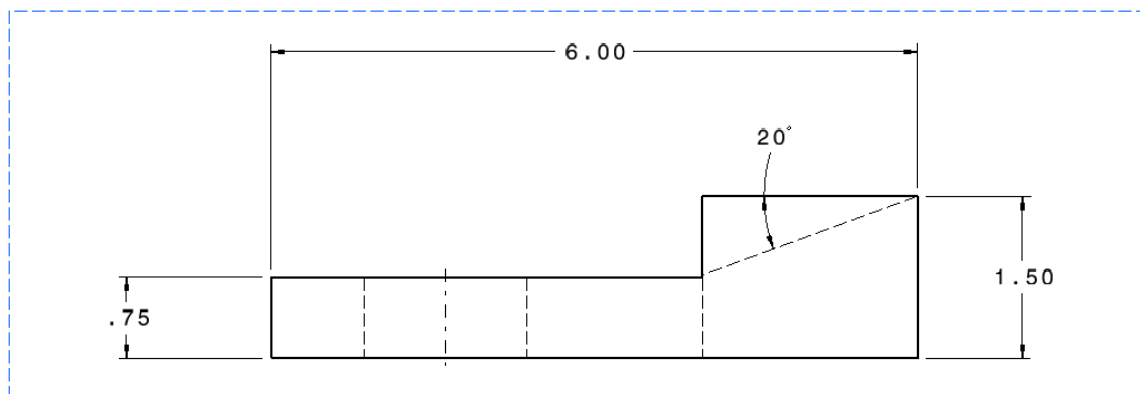

Save your drawing and close all documents.

Annotations

Annotations and symbols are normally required to finish a drawing. Annotations are used to convey notes and information to the downstream user. Symbols are used to represent items such as part numbers and welds. This section will cover the various tools you have available to create annotations and symbols.

Creating Text

Open the Annotations drawing and part. This will allow you to work with items in both windows. The drawing should contain four views with the *FRONT VIEW* active.

Select the Text icon.  It is located under the Datum Target icon. This will allow you to create text.

Select a location in the *FRONT VIEW* to the right of the extension. This defines the anchor point for the text. A *Text Editor* window appears. In this window you can type your text.

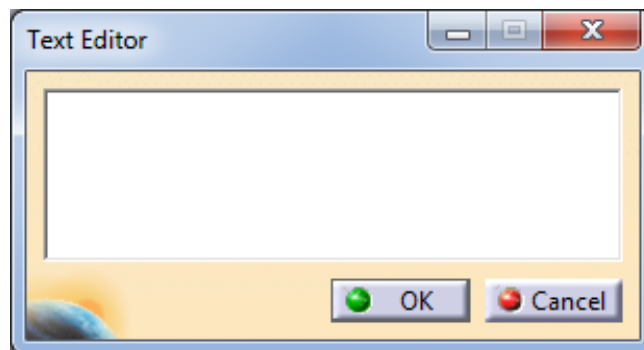

Key in WATCH FOR EXTENSION and select *OK*. The text appears. You can drag the text around to any location by using the first mouse button.

Drag the text to the approximate location as shown below.

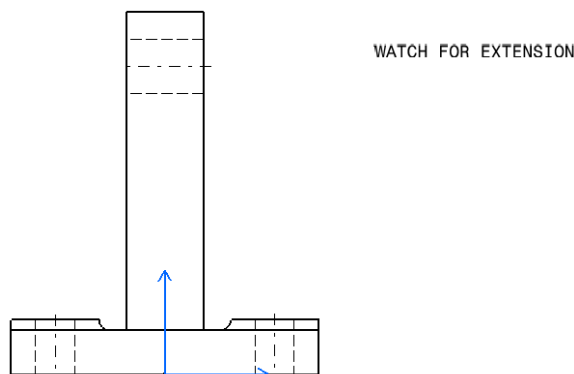

Create text that says TO THE RIGHT underneath and to the right of the last one.

Create text that says TO THE LEFT underneath and to the left of the first piece of text. Now you will create text that is associated to a piece of geometry.

Select the **Text** icon and then select the left vertical line of the extension.  The *Text Editor* appears.

Key in **LEFT SIDE** and select **OK**. The text appears.

Drag the text to the left of the extension as shown below.

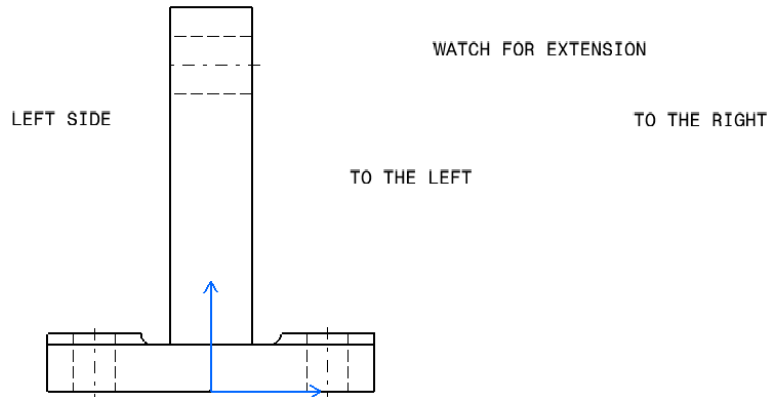

Notice that all of the text has the same graphical properties. You can set the properties of the text before you create it by using the top toolbar. However, you will investigate these options when you modify text.

Select the **Text** icon and position the text below and to the right of the geometry in the view. 

Key in **THIS IS** press **Shift-Enter**, key in **A MULTI-LINE** press **Shift-Enter**, key in **PIECE OF TEXT** and select **OK**. This should create a string of text that spans three lines as shown below. You have to press the Shift key along with Enter in order to add an additional line of text.

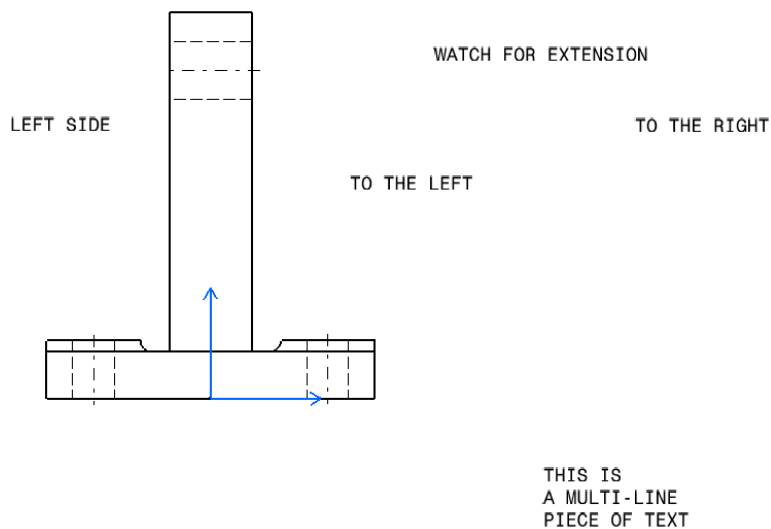

Make the **TOP VIEW** active. You are now going to create text with a leader.

Select the **Text with Leader** icon.  It is located under the Text icon. You will select an element to position the anchor point of the arrow head.

Select the **small circle on the right**. You should see an arrow appear that you can drag to position the anchor point of the text.

Drag the arrow up and to the right and define the anchor point for the text. The *Text Editor* window appears.

Key in **HOLE** and select **OK**. You have some positioning manipulators appear. Position the text as shown below and select in the view off the text. The text with leader is created.

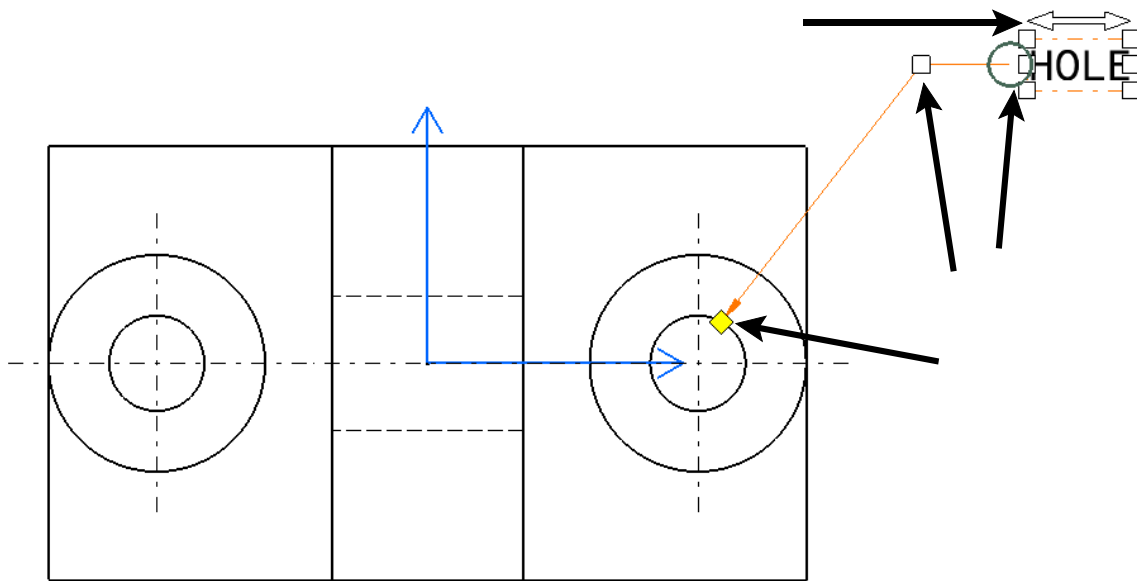

Those are the options that you have to create text. There are a lot of modifications that you can perform on the text, however. You will explore these modifications next.

Modifying Text

There are many options to modify text, a lot of these options you can perform before you create the text. Most of the common options are located in the top toolbar.

Top Toolbar

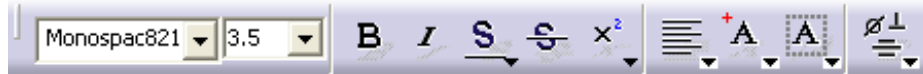

These options allow you to change the font, font size, bold, italic, underline, strike through, overline, superscript, subscript, justification, anchor point, frame and symbols. You will try out each option next.

Font properties

Make the **FRONT VIEW** active.

Select **THIS IS A MULTI-LINE PIECE OF TEXT**. You can now modify the settings using the top toolbar.

Change the font type to **Times New Roman**. The text changes font.

Change the font size to **0.276**. The option might contain more decimal places, go ahead and select the option which is closest. The text becomes larger.

Note: If the box is showing less than three decimal places, press the third mouse button while on the box and select Set precision. A Set precision window will appear. Change the Precision to 3 and select OK.

Select the **Bold icon**.  The text should appear bold. This is a toggle therefore you can select it again to turn the bold off.

Select the **Bold icon again**.  The bold is removed.

Select the **Italic icon**.  The text appears in italics.

Select the **Italic icon again**.  The italics is removed.

Select the **Underline icon**.  All three lines of text appear underlined.

Select the **Underline icon again**.  The underline is removed.

Select the **Strikethrough icon**.  All three lines of text are struck through.

Select the **Strikethrough icon again**.  The strike through is removed.

Select the **Overline icon**.  It is located under the underline icon. All three lines of text appear with an overline.

Select the **Overline icon again**.  The overline is removed.

Select the **Superscript icon**.  The text appears superscripted.

Select the **Superscript icon again**.  The superscript is removed.

Select the **Subscript icon**.  It is located under the superscript icon. The text appears subscripted.

Select the **Subscript icon again**.  The subscript is removed.

You should realize that you can have more than one property assigned to text at a given time. It is possible to have a piece of text be bold, italic, underlined or overlined, struck through, superscript or subscript. The only options that cannot be on at the same time is underline and overline; and superscript and subscript.

Justification

You can also adjust the justification using the toolbar to be either left, center or right. This will only appear when you have multiple lines in the same piece of text.

Select the Center Justification icon.  It is located under the Left Justification icon. You should notice that this text is already left justified. The text should become center justified.

Select the Right Justification icon.  It is located under the Center Justification or Left Justification icon. The text should become right justified.

Select the Left Justification icon.  The text should become left justified.

Notice that only one type of justification can be used per line on a piece of text. In other words you can not have the text be right and left justified.

Anchor point

You can position your text with respect to the anchor point. This does not change the position of the anchor point but instead positions the text differently with respect to the anchor point.

Select the arrow on the Anchor Point icon.  The anchor point options should appear. Whatever appears on the icon is how the text is positioned in respect to the anchor point. Currently it is positioned so that the anchor point is in the upper left corner of your text. You will change the anchor point a couple of times.



Select the center Anchor Point option.  Notice the text moved to the left and up in order for the anchor point to be in the center of the text.

Select the bottom right Anchor Point option.  Notice the text moved to the left and up again in order for the anchor point to be in the lower right corner. Continue to play with the different anchor locations.

Select the top left Anchor Point option.  Your text returns to its original location.

Frame

You have the option to add a variety of frames to your text. You will explore a few of them.

Select the Frame drop-down menu. A list of frames appears.

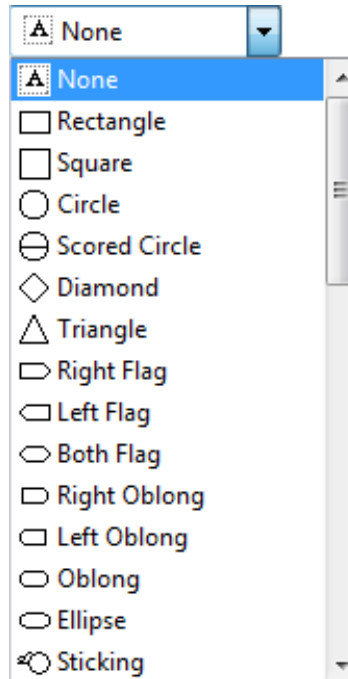

The frames with the little locks on them are fixed sized frames defined in the standards file. This becomes useful when your company has a set size for certain frames and it is up to you to fit your text within the frame by modifying its size. The other ones are variable sized frames and will adjust to fit the text.

Select the rectangle Frame option.  A rectangular frame appears around the text.

Select the circle Frame option.  A circular frame appears around the text.

Select the left flag Frame option.  Feel free to play around with the other frame options but make sure you set the frame to this option before continuing.

Insert Symbol

You also have the option of inserting a symbol. The symbol will be inserted at the end of the text unless you edit the text then you can have the symbol insert anywhere within the text.

Select the arrow on the **Insert Symbol icon**.  This will allow you to specify what symbol you would like to insert.



Select the **Centerline option**.  The centerline symbol is inserted at the end of your text.

Select the **Degree option**.  The degree symbol is inserted at the end of your text. Notice that your text contains the centerline symbol and the degree symbol.

Double select on the text with the first mouse button. The *Text Editor* window appears. Your text is in the window along with the two symbols.

Remove the two symbols. You can do this by selecting at the end of the text and backspacing.

Select at the end of the first line. This will set the insert location to be at the end of the first line.

Select the **Triangle option**.  The triangle symbol appears at the end of the first line.

Remove the triangle and select OK. This will switch the text to contain no symbols.

Select off the text inside the view. This releases the text.

Your drawing should look like the diagram shown below.

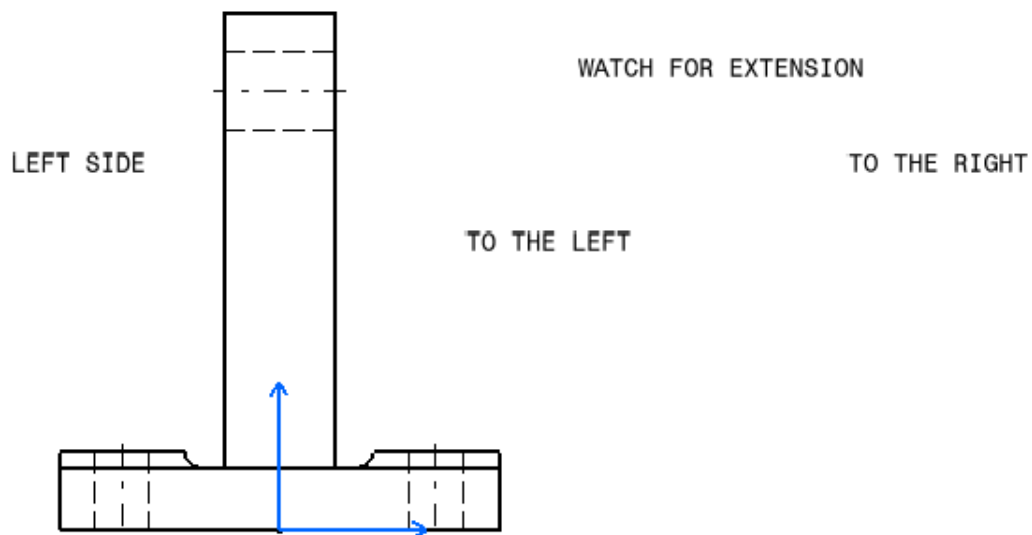
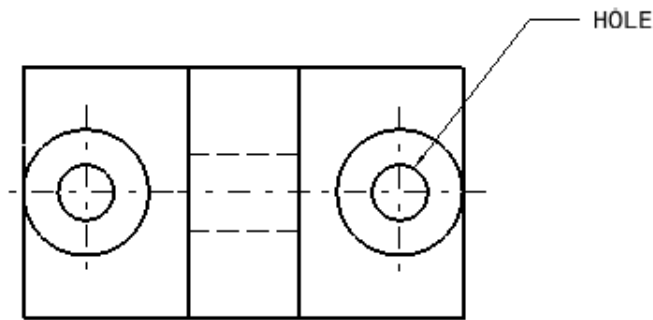

THIS IS
A MULTI-LINE
PIECE OF TEXT