



National Center for Additive Manufacturing Excellence

Factors Affecting Qualification/Certification - Surface Integrity of Additively Manufactured Ti-6Al-4V Parts

Erfan Maleki, Nabeel Ahmad, Shuai Shao, Nima Shamsaei

Project sponsored by: Federal Aviation Administration (FAA)

May 2024 Long beach, CA

Introduction

- **Project Title:** Factors Affecting Qualification/Certification - Surface Integrity of Additively Manufactured Ti-6Al-4V Parts
- **Principal Investigator:** Nima Shamsaei
(See next slide for complete list of participants.)
- **FAA Technical Monitor:** Kevin Stonaker
- **Source of matching contribution:** Faculty time and graduate research assistant tuition



Project Team



Kevin Stonaker
Project Manager
FAA TPOC

Aziz Ahmed

Michael Gorelik

Cindy Ashforth

Jeffrey D Stillinger

John Bakuckas

Walter Sippel

Thomas F Broderick

Aklilu Yohannes

Advisory Group



Jim Dobbs
Boeing



Jeffrey Gaddes
US Army



Richard Grylls
Beehive3D



Frederic Marrison
GE Additive



Mahdi Habibnejad
GE Additive



Mohsen Seifi
ASTM Int.



Brandon Phillips
US Army



Katherine Olson
US Army



Ankit Saharan
EOS – N.A.

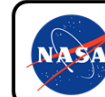

Douglas Wells
MSFC, NASA



NCAME Project Team
Auburn University

8 Senior Investigators

8 Graduate Research Assistants

PI: Nima Shamsaei (Mechanical Engr.)

Co-PIs:

Shuai Shao (Mechanical Engr.)

Robert Jackson (Mechanical Engr.)

Kyle Schulze (Mechanical Engr.)

Daniel Silva Izquierdo (Indus. Sys. Engr.)

Aleksandr Vinel (Indus. Sys. Engr.)

Jia Liu (Indus. Sys. Engr.)

Background

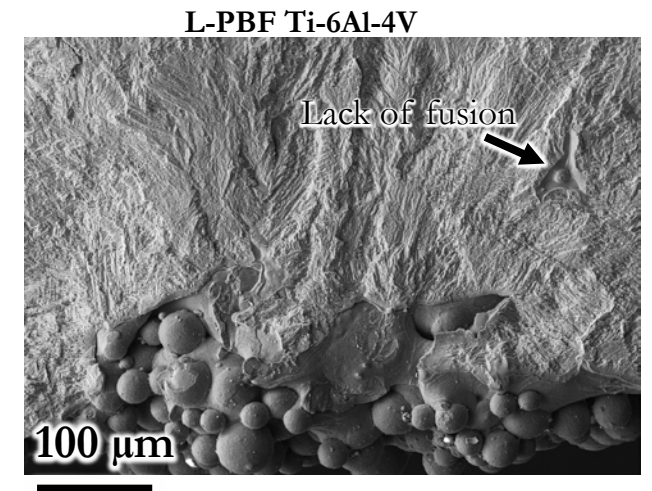
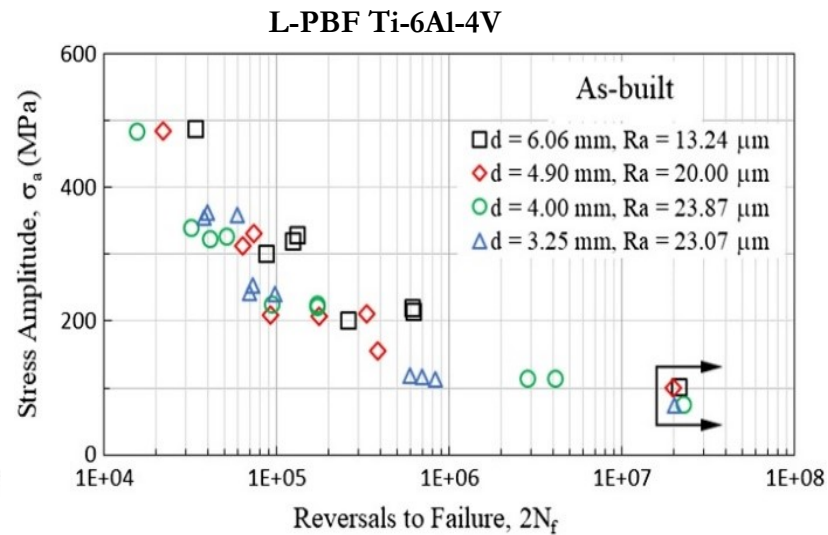
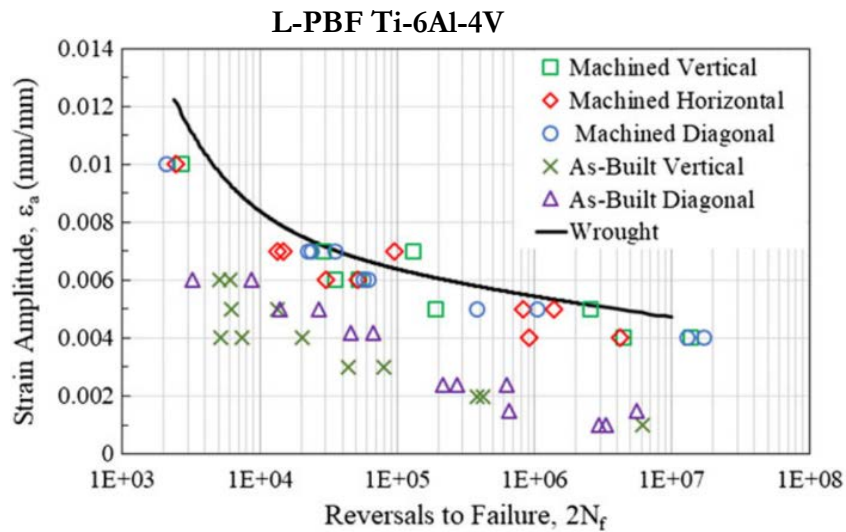

- The fatigue lives of L-PBF Ti-6Al-4V specimens in as-built surface are often shorter compared to the specimens with machined surface condition
- Fatigue cracks in specimens with as-built surface typically initiate from micro-notches on the rough surface
- In some cases, one or two volumetric defects, often gas entrapped pores, are also found near the crack initiation site
- The fatigue strength appears to decrease with the increase in surface roughness

Background

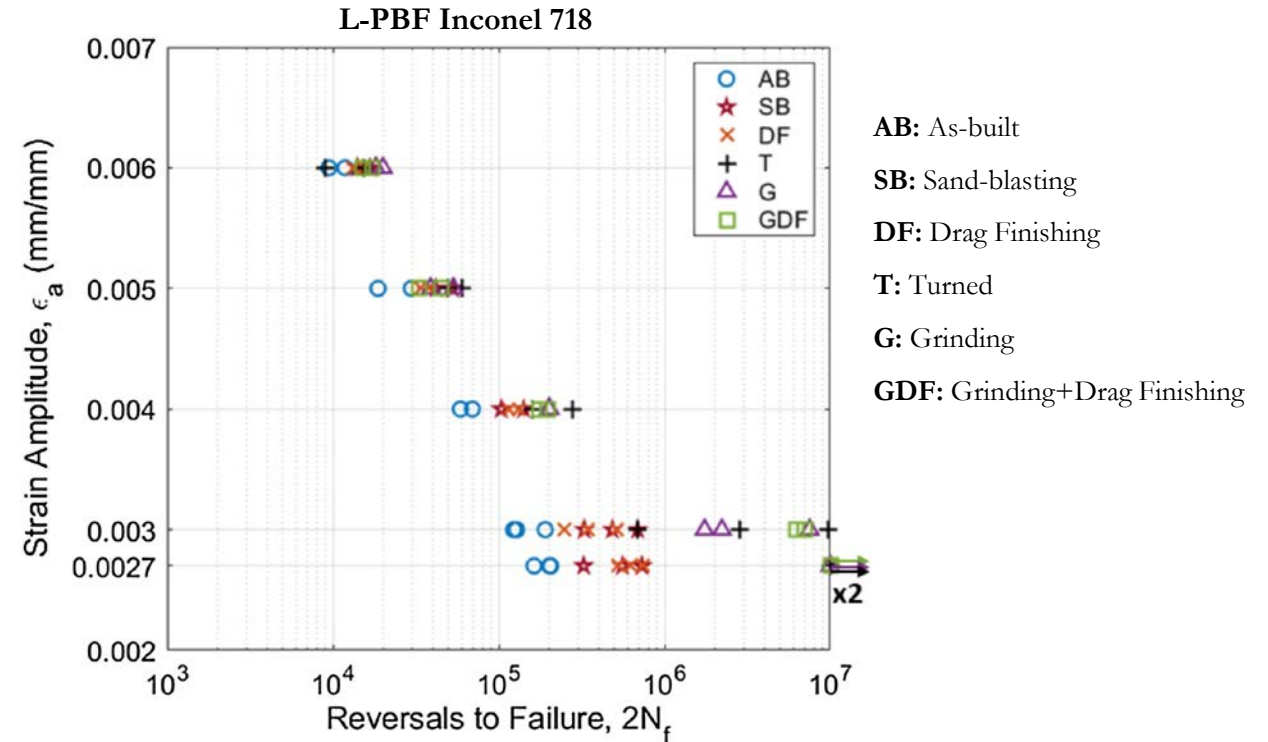
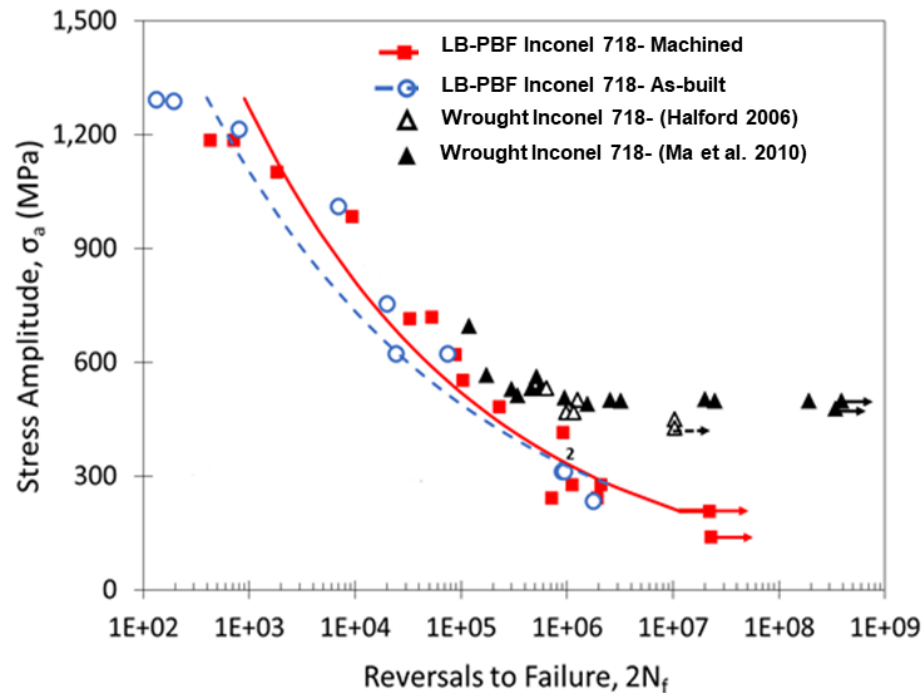

- Different surface treatments can improve fatigue life to different extents
- Efficacy of surface treatments depends on the material and selected parameters
- Insufficient machining depth may expose near-surface pores to the surface

Challenge

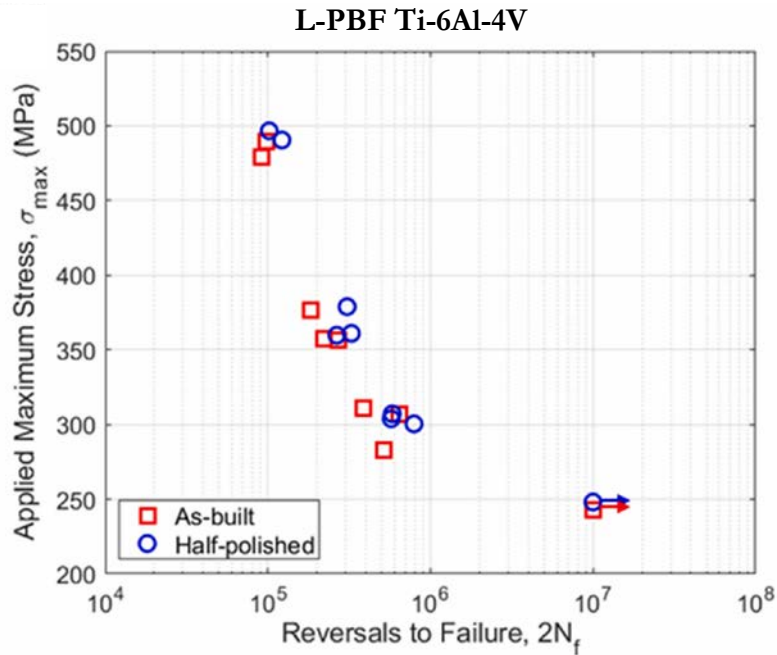

Surface texture parameters	As-built		Half-polished	
	Line	Area	Line	Area
Arithmetical mean height (Ra or Sa)	18.8 μm	19.8 μm	9.0 μm	11.6 μm
Root mean square deviation (Rq or Sq)	23.2 μm	24.5 μm	11.0 μm	14.0 μm
Maximum profile peak height (Rp or Sp)	62.8 μm	111.8 μm	15.5 μm	31.0 μm
Maximum profile valley depth (Rv or Sv)	58.7 μm	87.7 μm	35.2 μm	56.7 μm

- Although standard surface parameters for as-built and half-polished specimens differ by almost a factor of two, fatigue lives of half-polished specimens did not improve
- Standard surface parameter could not capture the effect of surface texture on the fatigue behavior of AM parts

Challenge

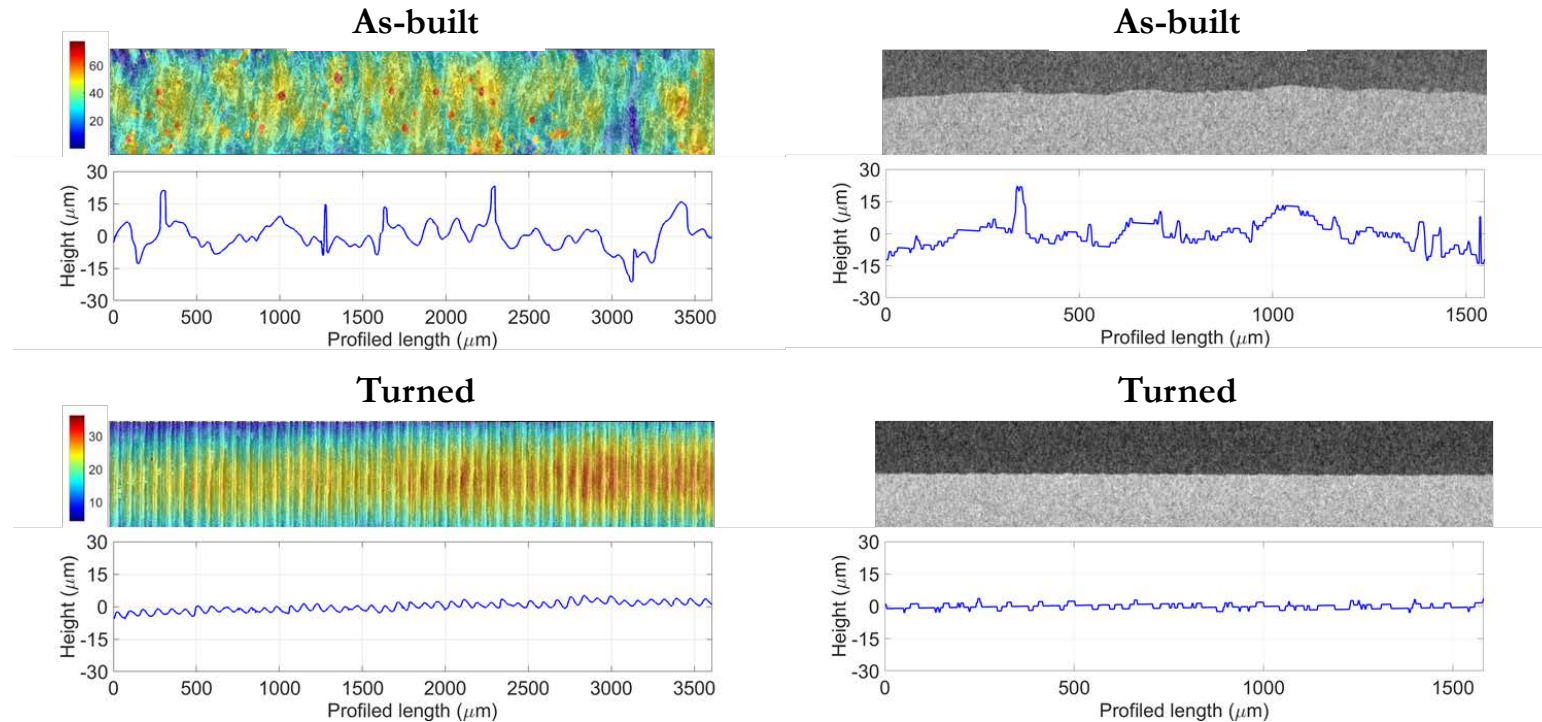

- The applicability of different non-destructive inspection (NDI) techniques to measure the surface texture of AM parts has not been thoroughly studied
- While x-ray computed tomography (XCT) can capture surface texture and subsurface volumetric defects, it is costly to use and the resolution may not be adequate
- Depending on the measurement technique employed, the calculated values of standard surface parameters may vary

Objective & Approach

- **Objective:** Factors Affecting Qualification/Certification - Understand the Effects of Surface Integrity on Mechanical Behaviour of Additively Manufactured Ti-6Al-4V
- **Approach:** Four steps are taken,
 - I. Explore the effect of key process variables and/or post-processing on surface and near-surface conditions
 - II. Evaluate the effectiveness of NDI techniques to assess their capability of detecting material and manufacturing critical anomalies on the surfaces and near-surface
 - III. Determine the combined effect of surface and near-surface defects on tensile behavior and fatigue life
 - IV. Identify the key influencing defect features on tensile and fatigue properties and establish appropriate metrics for characterizing surface conditions

Fabrication and Testing Equipment



AP&C Ti-6Al-4V Grade 5 powder



EOS M290 L-PBF



MTS Fatigue Testing



Scanning Electron Microscope



XCT



Keyence



Dektak



SWLI

- XCT, Keyence, Dektak, and SWLI were used to measure surface texture

Objective & Approach

- **Objective:** Factors Affecting Qualification/Certification - Understand the Effects of Surface Integrity on Mechanical Behaviour of Additively Manufactured Ti-6Al-4V
- **Approach:** Four steps are taken,
 - I. Explore the effect of key process variables and/or post-processing on surface and near-surface conditions
 - II. Evaluate the effectiveness of NDI techniques to assess their capability of detecting material and manufacturing critical anomalies on the surfaces and near-surface
 - III. Determine the combined effect of surface and near-surface defects on tensile behavior and fatigue life
 - IV. Identify the key influencing defect features on tensile and fatigue properties and establish appropriate metrics for characterizing surface conditions

DoE: XCT Coupons

Condition	Laser order 1	Laser order 2	Laser order 3	P	V	h
Recommended	Infill	20 μm	0 μm	280	1200	0.14
LoF				252	1200	0.14
LoF				224	1200	0.14
LoF				280	1200	0.17
KH				364	960	0.14
KH				336	840	0.14
No contour	N/A	N/A	N/A			
Contour order	Offset, 20 μm	Offset, 0 μm	Infill			
Contour order	Offset, 20 μm	Infill	Offset, 0 μm			
Contour order	0 μm	Infill	Offset, 20 μm			
Single contour	Infill	Offset, 20 μm	N/A			
Single contour	Infill	Offset, 0 μm	N/A			
Different offset	Infill	Offset, 40 μm	Offset, 20 μm			
Different offset	Infill	Offset, 40 μm	Offset, 0 μm			

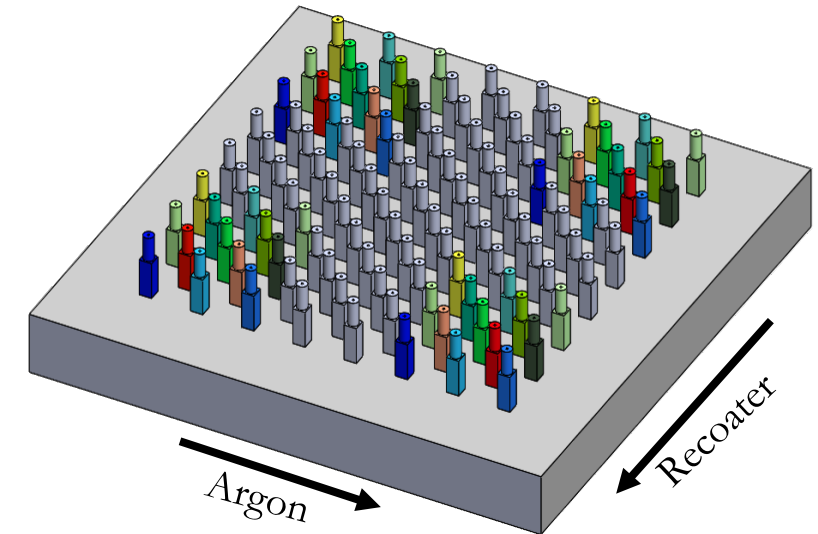
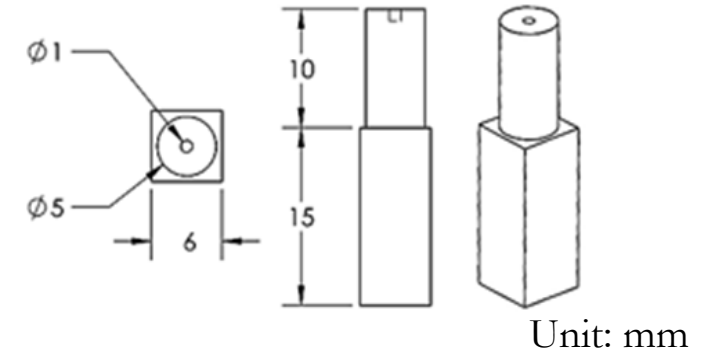

- 14 different key process variables were considered

Coupon colors correspond to different process parameters, which are shown using corresponding color in the table

Results: Selection of Process Parameters

Geometry	Orientation	Contour	Infill	Sa (μm)	Sv (μm)	Surface Treatment
Solid	Vertical	No contour	Default	19	135	No
Solid	Vertical	No contour	KH	15	120	No
Solid	Vertical	No contour	LoF	21	141	No
Solid	Vertical	Order of contours	Default	20	74	No
Solid	Vertical	Order of contours	Default	20	70	No
Solid	Vertical	Order of contours	Default	19	76	No
Solid	Vertical	1 contour	Default	20	88	No
Solid	Vertical	1 contour	Default	17	75	No
Solid	Vertical	Different offsets	Default	21	92	No
Solid	Vertical	Different offsets	Default	17	70	No
Solid	Vertical	Default	KH	19	79	No
Solid	Vertical	Default	KH	21	83	No
Solid	Vertical	Default	LoF	21	75	No
Solid	Vertical	Default	LoF	18	62	No
Solid	Vertical	Default	LoF	20	93	No
Solid	Vertical	Default	Default	21	81	No

Note: Green shading indicates selected process parameters for fabrication of tensile and fatigue specimens

- Reported Sa and Sv values were obtained using SWLI

Post-processing: XCT

Flow chart for XCT image processing

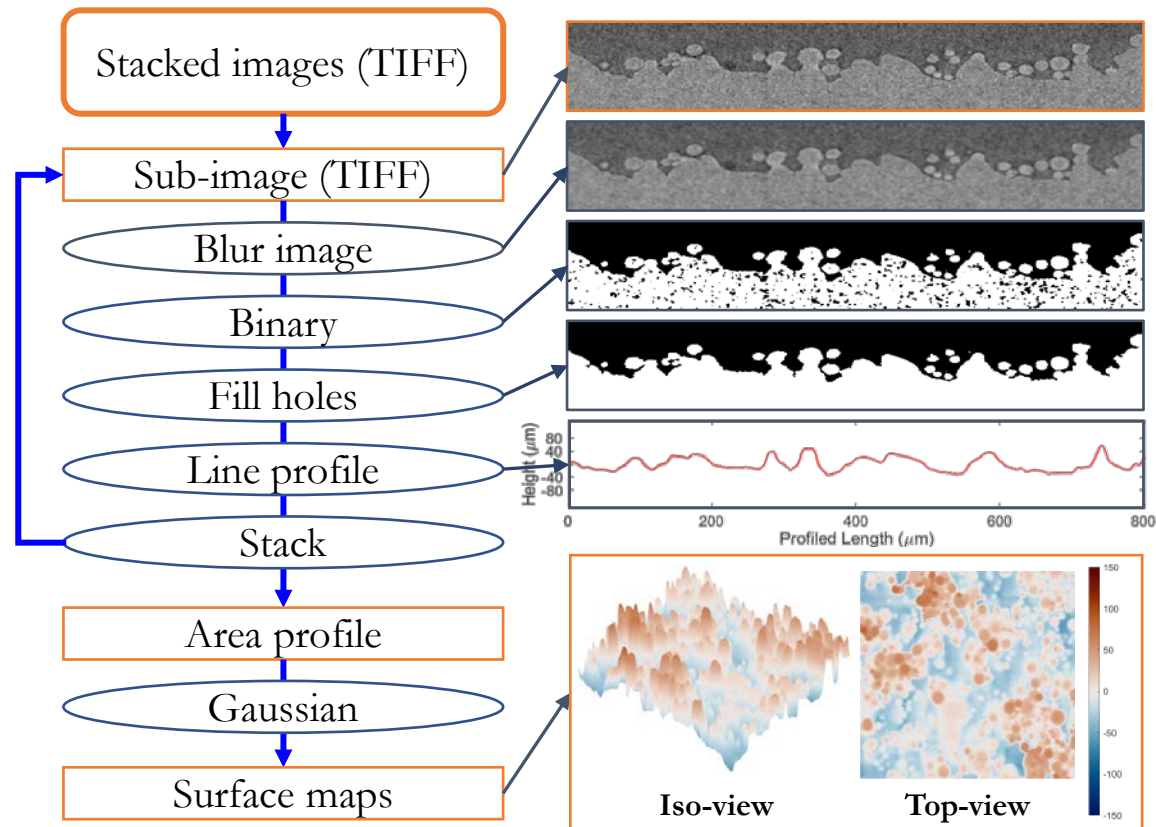

Implications from overhang structures

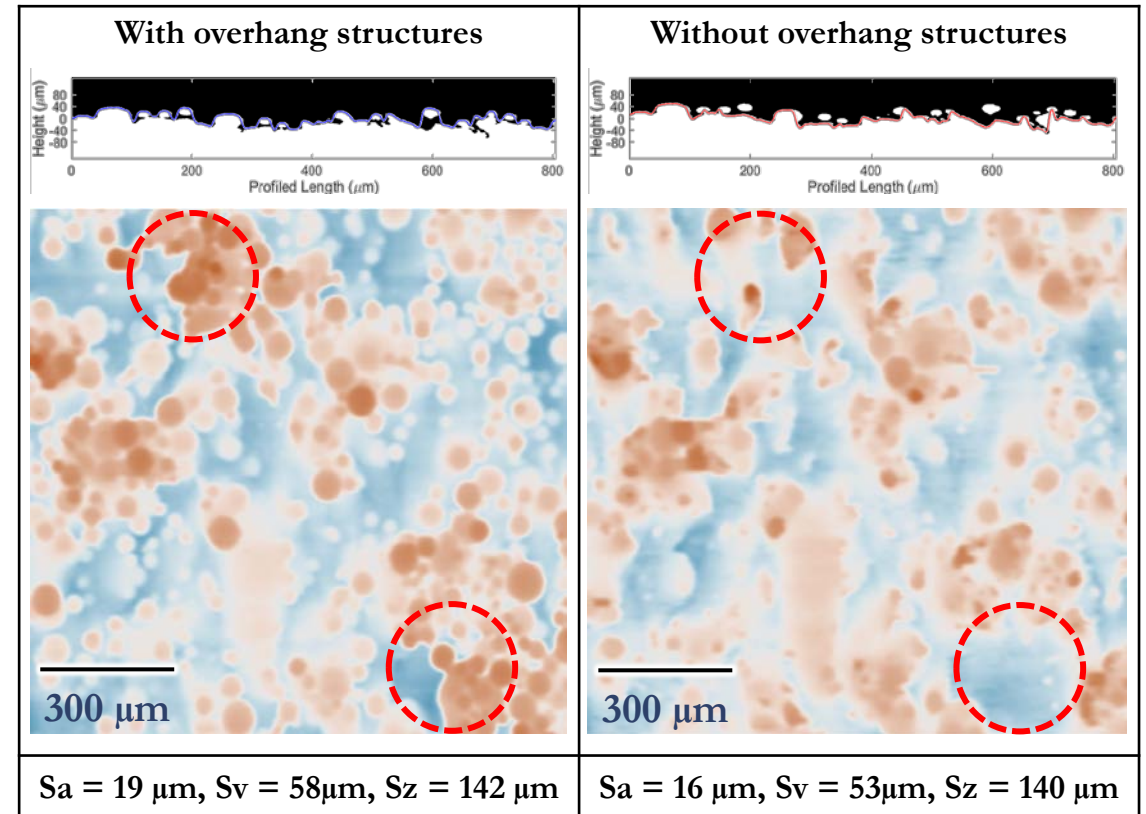

- Surface topography was obtained by stacking line profiles

Preliminary Surface Texture Results from Specimens

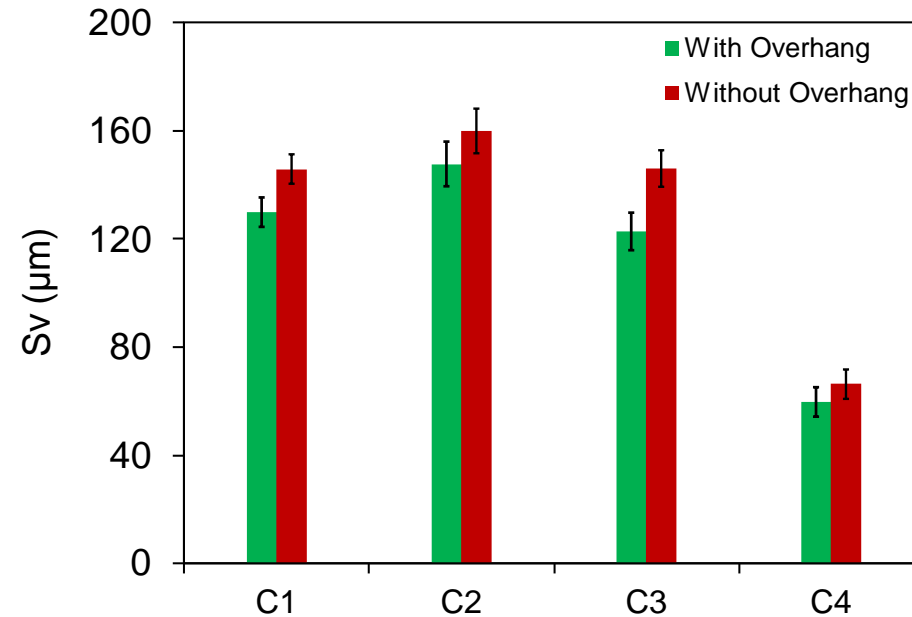
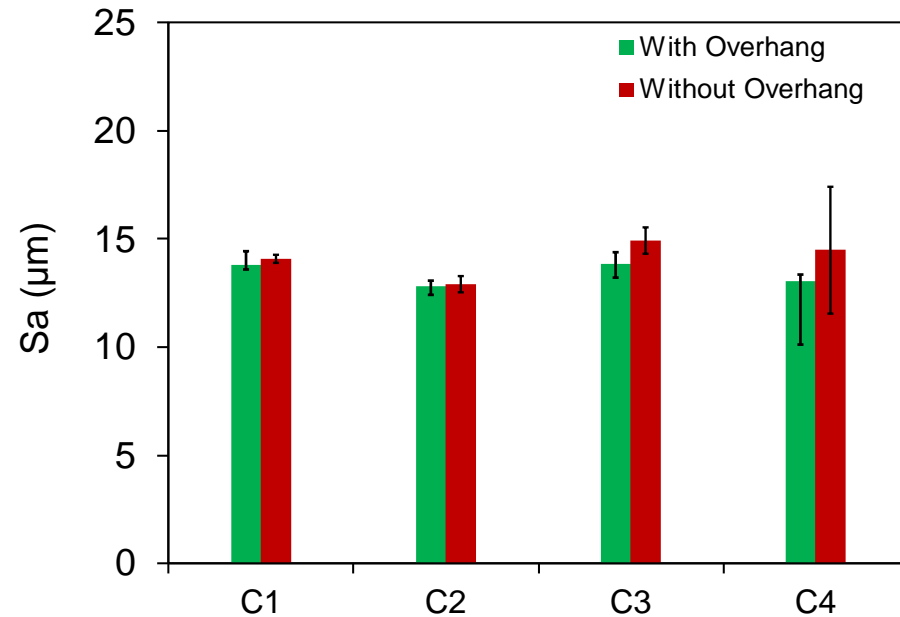

C1: No Contour & Default Infill; **C2:** No Contour & Keyhole; **C3:** No Contour & Lack of Fusion; **C4:** Default Contour & Default Infill

- As expected, without overhang approach could capture valleys better than with overhang approach
- Specimens without contour (C1, C2, & C3) showed deeper Sv values
- Sa exhibited no significant variations with changes in process parameters

Objective & Approach

- **Objective:** Factors Affecting Qualification/Certification - Understand the Effects of Surface Integrity on Mechanical Behaviour of Additively Manufactured Ti-6Al-4V
- **Approach:** Four steps are taken,
 - I. Explore the effect of key process variables and/or post-processing on surface and near-surface conditions
 - II. Evaluate the effectiveness of NDI techniques to assess their capability of detecting material and manufacturing critical anomalies on the surfaces and near-surface
 - III. Determine the combined effect of surface and near-surface defects on tensile behavior and fatigue life
 - IV. Identify the key influencing defect features on tensile and fatigue properties and establish appropriate metrics for characterizing surface conditions

Overview of NDI Techniques

Dektak

Advantages:

-Measurements can be obtained quickly

Disadvantages:

-Requires continuous contact with the surface

-Performs line scans not area

Cost:

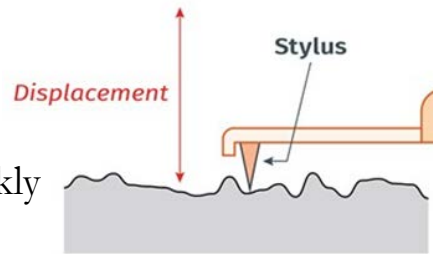

Cost	~\$10,000
Scan Time	2 Minutes

Keyence

Advantages:

-Measurements can be obtained quickly

Disadvantages:

-Glare can cause outliers in the data

-Resolution is not as fine as other methods

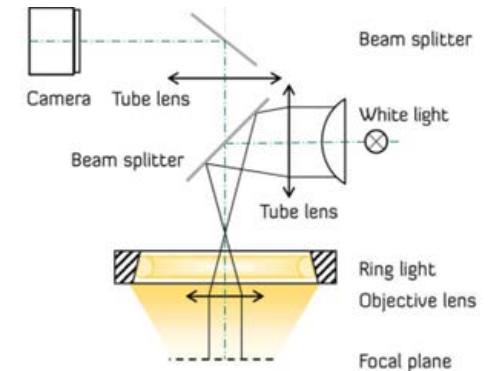

Cost	~\$60,000
Scan Time	6 Minutes

SWLI

Advantages:

-Measurement can achieve sub-nanometer precision in height

Disadvantages:

-Cannot read spiky or nonreflective asperities

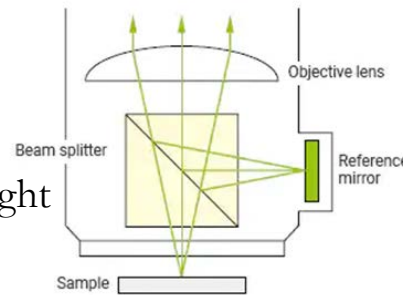

Cost	~\$200,000
Scan Time	40 Minutes

XCT

Advantages:

-Subsurface defects can be detected

Disadvantages:

-Scan time can be long

-Requires heavy post processing

X-ray source

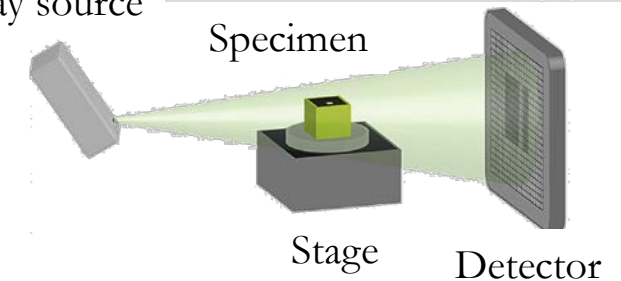

Cost	~\$1,000,000
Scan Time	>2.5 hours

Results: Surface Texture from the Matching Areas

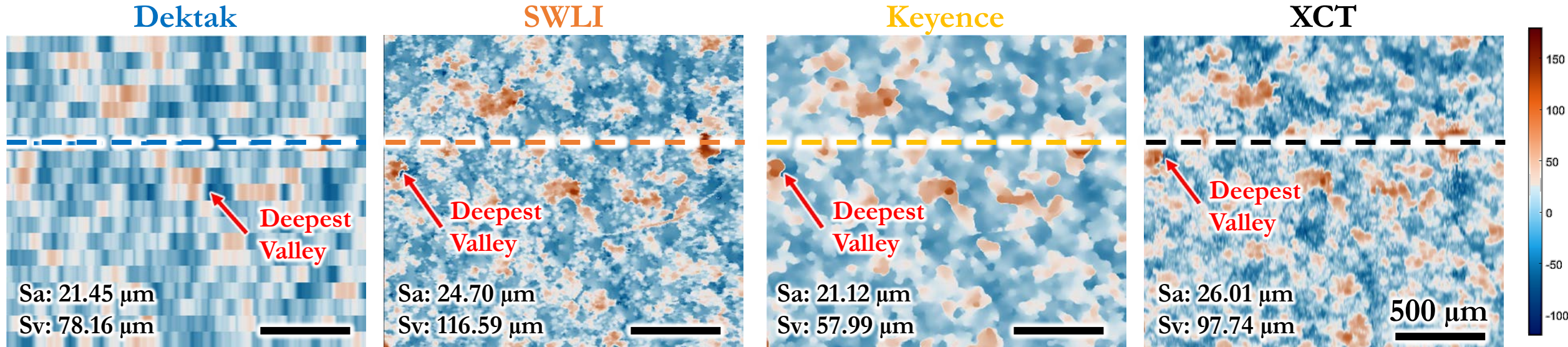

- XCT surface topography with overhang structures showed similar results to other techniques
- Dektak and Keyence showed lower roughness values compared to SWLI and XCT
- Surface profile obtained from polished cross-section was similar to XCT profile, indicating XCT results are more representative of the true profile

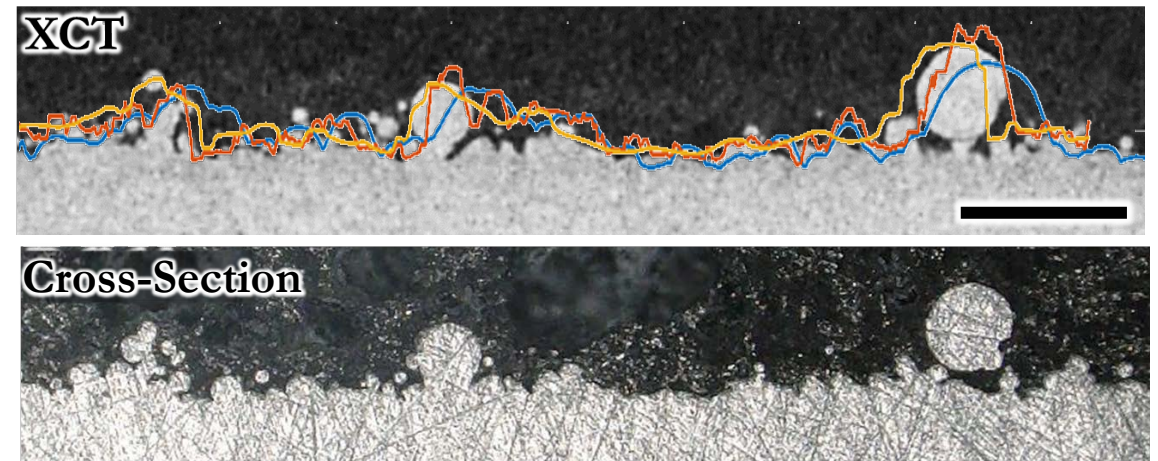

Objective & Approach

- **Objective:** Factors Affecting Qualification/Certification - Understand the Effects of Surface Integrity on Mechanical Behaviour of Additively Manufactured Ti-6Al-4V
- **Approach:** Four steps are taken,
 - I. Explore the effect of key process variables and/or post-processing on surface and near-surface conditions
 - II. Evaluate the effectiveness of NDI techniques to assess their capability of detecting material and manufacturing critical anomalies on the surfaces and near-surface
 - III. Determine the combined effect of surface and near-surface defects on tensile behavior and fatigue life
 - IV. Identify the key influencing defect features on tensile and fatigue properties and establish appropriate metrics for characterizing surface conditions

DoE: Tensile and Fatigue Specimens

#Fatigue Specimens per Set	#Tensile Specimens per Set	Geometry	Orientation	Contour	Infill	Surface Treatment
15	6	Solid	Vertical	No contour	Default	No
15	6	Solid	Vertical	No contour	KH	No
15	6	Solid	Vertical	No contour	LoF	No
15	6	Solid	Vertical	Default	Default	No
15	6	Solid	Vertical	Default	KH	No
15	6	Solid	Vertical	Default	LoF	No
15	6	Solid	Vertical	1 contour	Default	No
15	6	Solid	Vertical	Different offset	Default	No
15	6	Solid	Vertical	Default	Default	S/M
15	6	Solid	Vertical	Default	Default	D/M
15	6	Solid	Vertical	Default	Default	M/P
15	6	Solid	Vertical	Default	Default	Only P
15	-	Tubular	Horizontal	Default	Default	No
15	-	Tubular	Horizontal	Default	Default	Yes
15	-	Tubular	Vertical	Default	Default	No
15	-	Tubular	Vertical	Default	Default	Yes

Tensile specimens (ASTM E8)

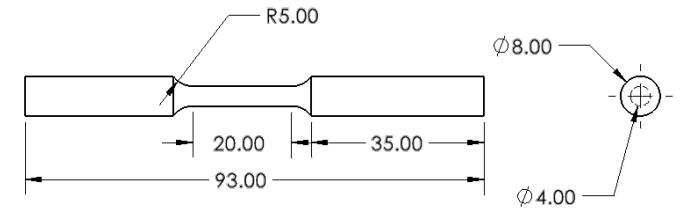

Fatigue specimens

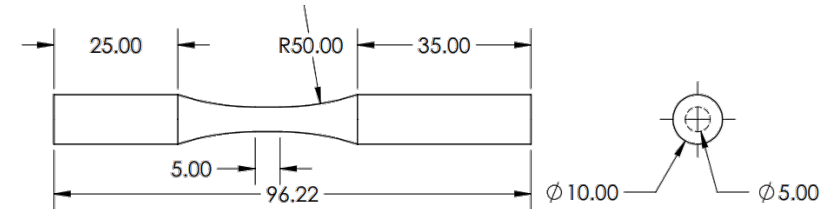

As-built tubular fatigue specimens

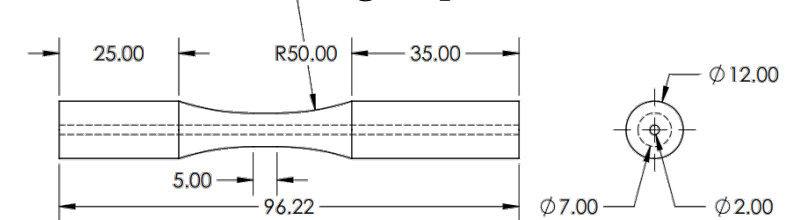

S/M: Shallow machining
D/M: Deep machining

M/P: Machining and polishing
P: Polishing

- 4 stress levels with 3 tests per level were chosen for each condition
- Geometries for D/M and S/M were oversized from outer diameter by 2 mm and 0.2 mm, respectively

Preliminary Fatigue Results

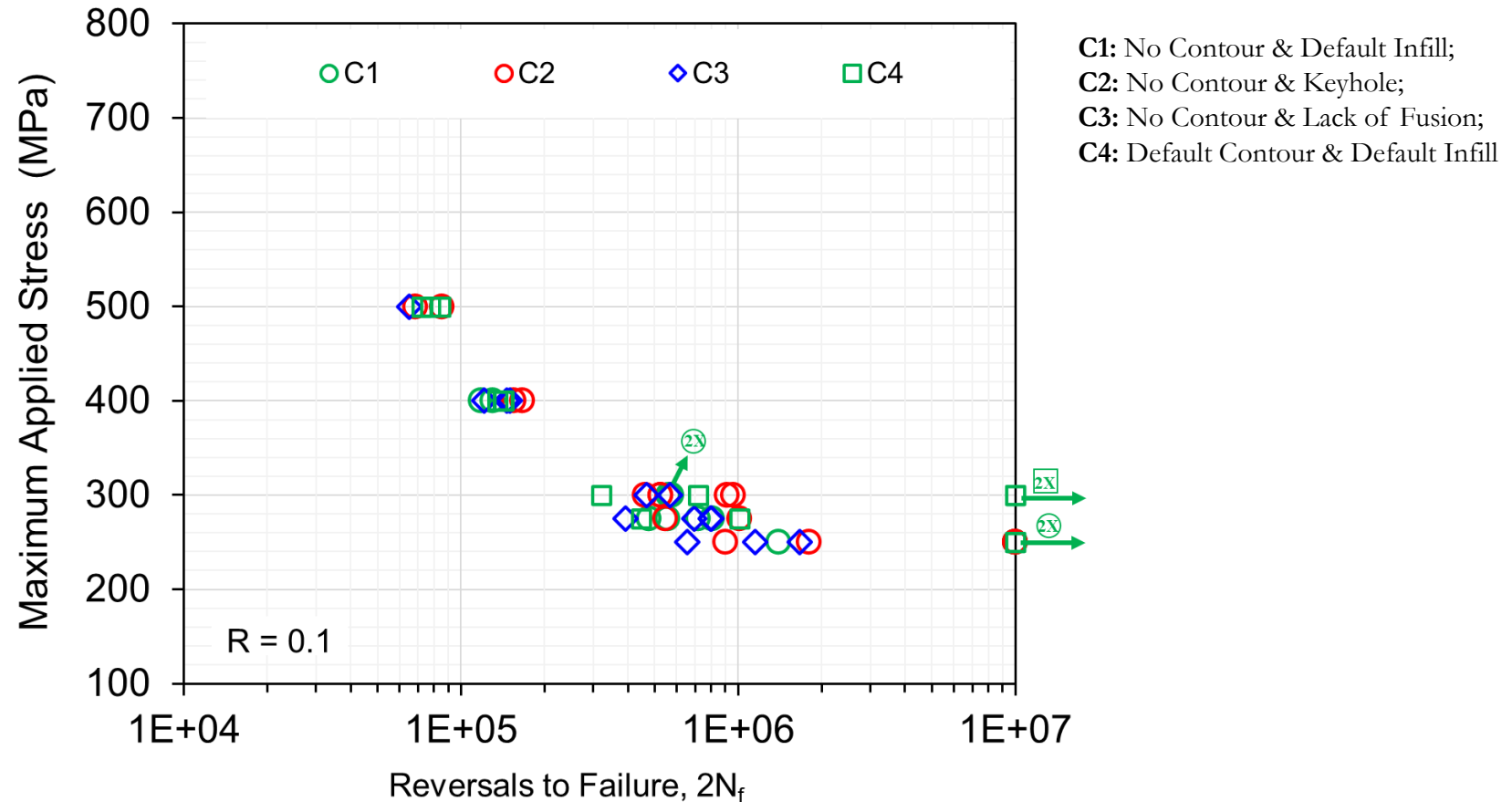

- There was very little effect of contouring and infill process parameters on the fatigue life

Matching Crack Initiating Defects

XCT Before Fatigue Testing

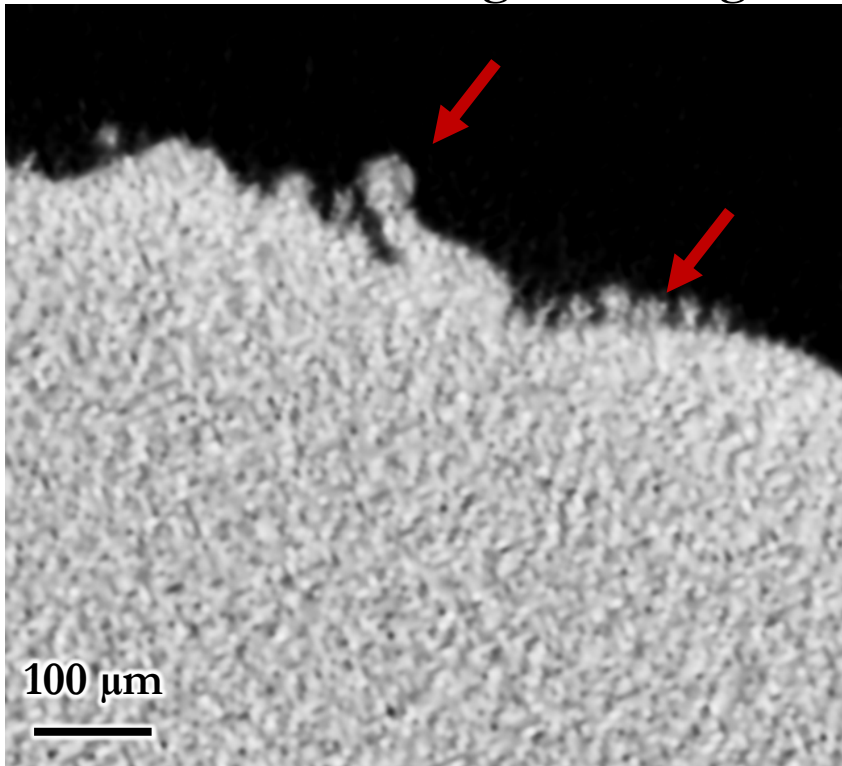

XCT After Fatigue Testing

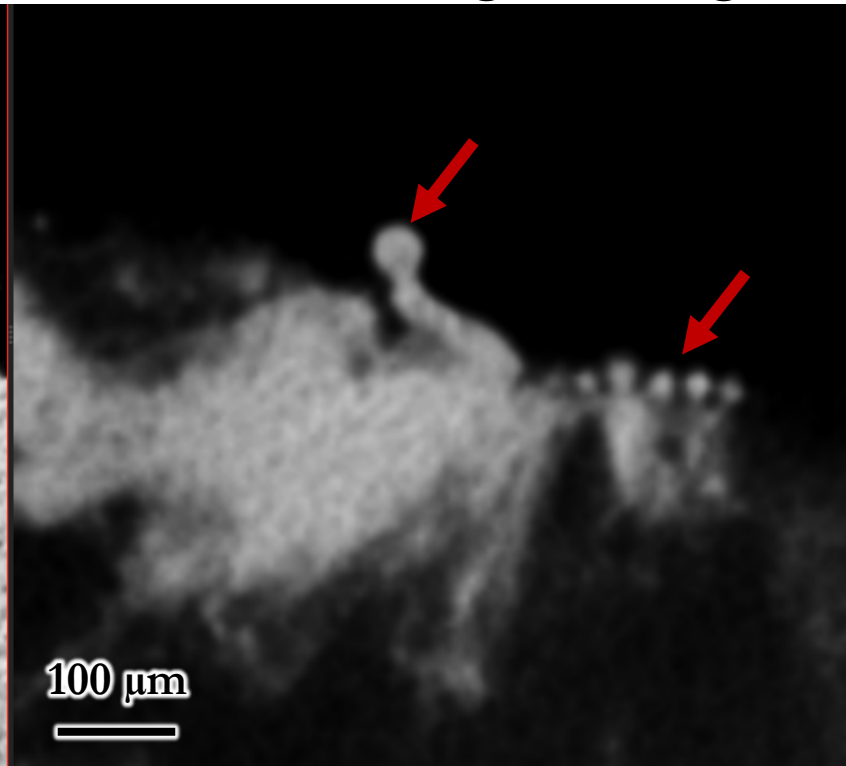

SEM Fractography

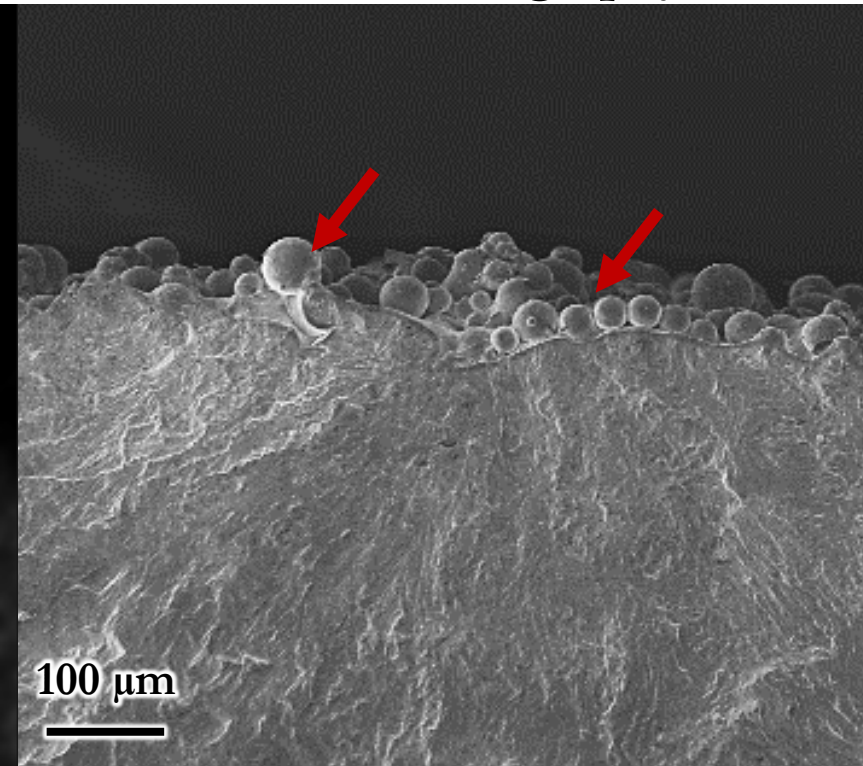

- XCT slices revealing crack initiating defects are indicative of the actual surface defects observed in the SEM fractographs
- The resolution of the scan limited the detection of very fine features

Summary

- Variation in infill process parameters did not affect surface texture values
- Specimens without contour exhibited deepest surface valleys
- In general, Dektak and Keyence showed lower surface texture values compared to the SWLI and XCT
- The surface texture values obtained from the XCT were dependent on the specific method used for processing the raw data
- Surface profile obtained from the XCT was more representative of the true profile obtained from the polished cross-section
- Absence of contour parameters led to reduced fatigue life

Thank You for Your Attention!

- National Center for Additive Manufacturing Excellence (NCAME)

