

JOINT ADVANCED MATERIALS & STRUCTURES
CENTER OF EXCELLENCE

Test Method Development for Environmental Durability of Bonded Joints

2013 Technical Review

Dan Adams, Larry DeVries

Clint Child, Nick Brown

University of Utah

FAA Sponsored Project Information

- Principal Investigators:
Dan Adams **Larry DeVries**
- Graduate Student Researchers:
Clint Child **Nick Brown**
- FAA Technical Monitor
David Westlund
- Primary Collaborators:
 - **Boeing: Kay Blohowiak and Will Grace**
 - **Air Force Research Laboratory: Jim Mazza**

Background:

Metal Wedge Crack Durability Test

ASTM D 3762, "Standard Test Method for Adhesive-Bonded Surface Durability of Aluminum (Wedge Test)"

- Bonded aluminum double cantilever beam specimen is loaded by forcing a wedge between the adherends
- Wedge is retained in the specimen
- Assembly placed into a test environment
 - Aqueous environment
 - Elevated temperature
- Further crack growth is measured following a prescribed time period

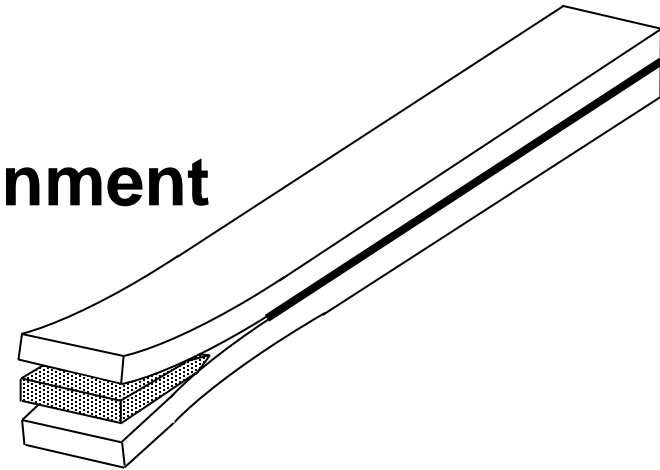

GENERAL PERCEPTIONS: Current ASTM D 3762 Standard

- Well-suited test methodology for assessing adhesive bond durability
- Standard includes a good description of test specimen
- Additional guidance needed in specimen manufacturing
- More detail required in test procedure
- Lacking sufficient guidance regarding conditions and requirements that constitute an acceptable metal bonded joint

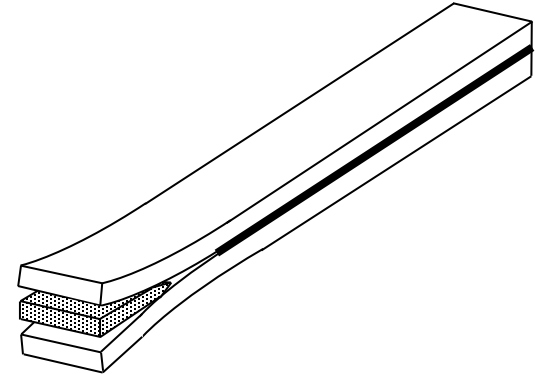

REVISION OF WEDGE TEST METHOD: Primary Areas Identified

Editorial Revisions

- Clarification of geometry
- Correction of procedure problems
- Improvement of figures

Specimen Preparation

- Controlling bondline thickness
- Machining specimens from panel

Testing Procedure

- Method of wedge insertion
- Measurement of initial crack length
- Specimen orientation during testing
- Specification of test environment

Interpretation of Results

- Role of initial crack length
- Role of crack growth
- Role of failure mode in test area

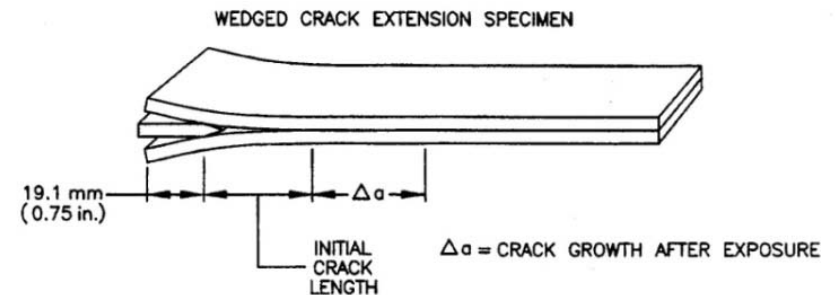
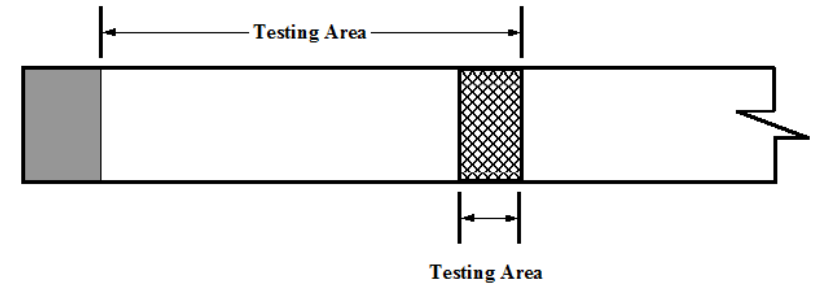

REVISION OF WEDGE TEST METHOD: Possible Levels of Additional Guidance

For the specimen/test parameter of interest, options include...

- Inform users that variations can affect results
- Report the value of the parameter used
- Suggest a value or range of values of the parameter
- Require a value or range of values of the parameter

EXAMPLE OF PROPOSED EDITORIAL CHANGE: Separation Film

Current:

9.2 Prime the faying surface of each panel, apply the adhesive, assemble the panels, and cure the adhesive as required by the appropriate specification. Insert a 50.8 by 152 by 0.10 mm (2 by 6 by 0.004-mm.) separation film along one of the 152-mm wide edges of the assembly as shown in Fig. 1 to omit the adhesive from between the separation film and the aluminum surface.

Proposed:

9.2 Prime the faying surface of each panel, apply the adhesive, **insert separation film**, assemble the panels, and cure the adhesive as required by the appropriate specification. **Insertion** of a 50.8 by 152 by 0.10 mm (2 by 6 by 0.004-in.) separation film along one of the 152-mm wide edges of the assembly as shown in Fig. 1 **omits** the adhesive from between the separation film and the aluminum surface **and facilitates insertion of the wedge. Measures should be taken to ensure that a uniform bondline thickness is produced across the entire panel during panel assembly and curing of the adhesive.**

EXAMPLE OF PROPOSED EDITORIAL CHANGE: Required Adherend Thickness

Current:

Note 4—The minimum permissible thickness in a uniform symmetrical adherend may be computed from the following relationship:

$$h = \sqrt{\frac{6Ta}{BF_{ty}}}$$

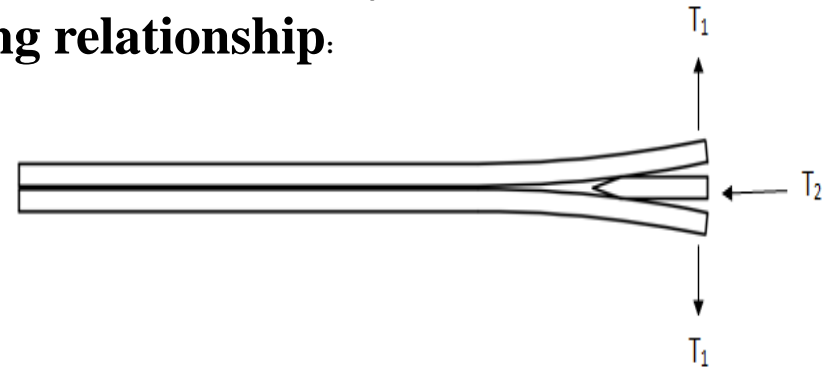

Proposed:

7.3 The **adherend yield point** and the **toughness of the adhesive** are the two most important factors in determining a satisfactory adherend thickness...

Note 4—The minimum permissible thickness in a uniform symmetrical adherend may be computed from the following relationship:

$$h = \frac{3G_c E}{F_{ty}^2}$$

AREA OF ADDITIONAL INVESTIGATION: Bondline Thickness Effects

- From literature: Bondline thickness can affect specimen performance
- No mention of bondline thickness control in ASTM standard
- Approach: Create multiple bondline thicknesses
 - Thickness gradient across panel
 - Constant thickness in panel with multiple panels
 - Adhesive: AF 163-2K film adhesive
 - Surface Preparation: PAA with BR 6747-1 bond primer
- Document effects:
 - Crack growth
 - Failure mode

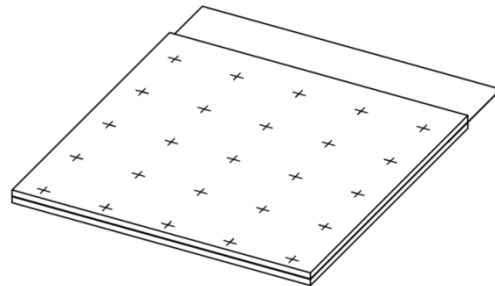

Bondline Thickness: Uniform Panel

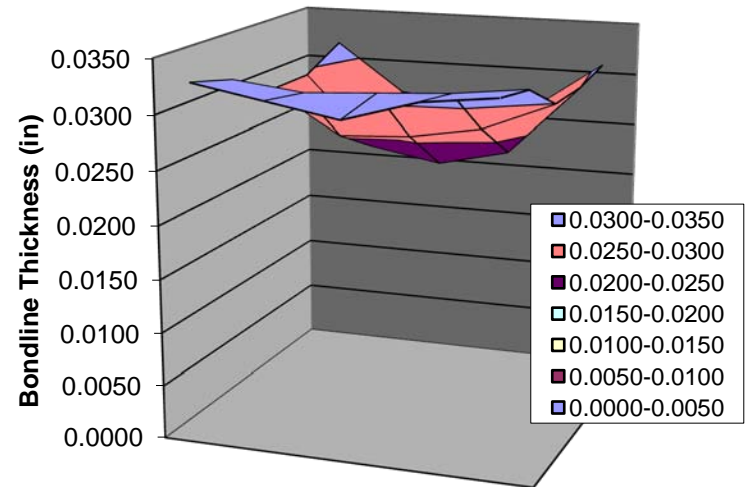

Bondline Thickness: Gradient Panel

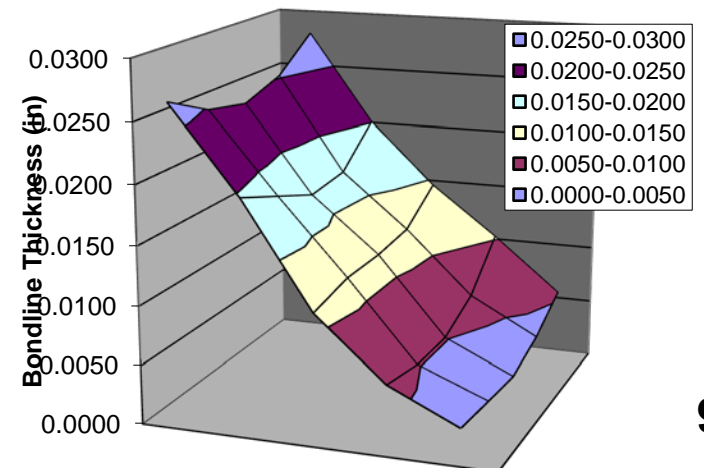

BONDLINE THICKNESS EFFECT: Initial & Final Crack Length

- Increasing the bondline thickness results in:
 - Decreased initial crack length (Immediately following wedge insertion)
 - Decreased final crack length (7 day exposure @ 50° C, 100%RH)

Initial Crack Length

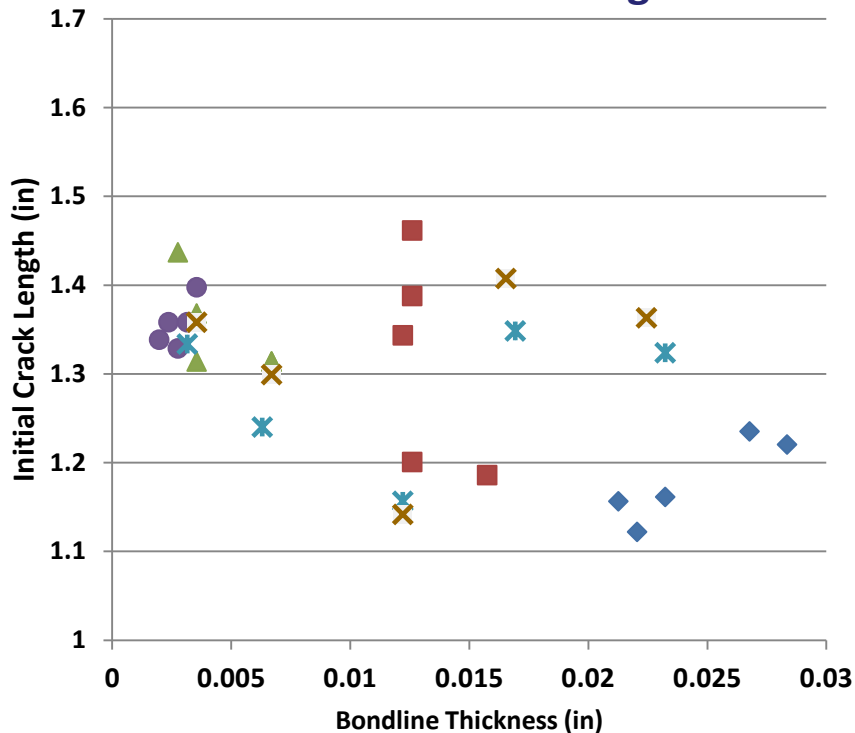

Final Crack Length

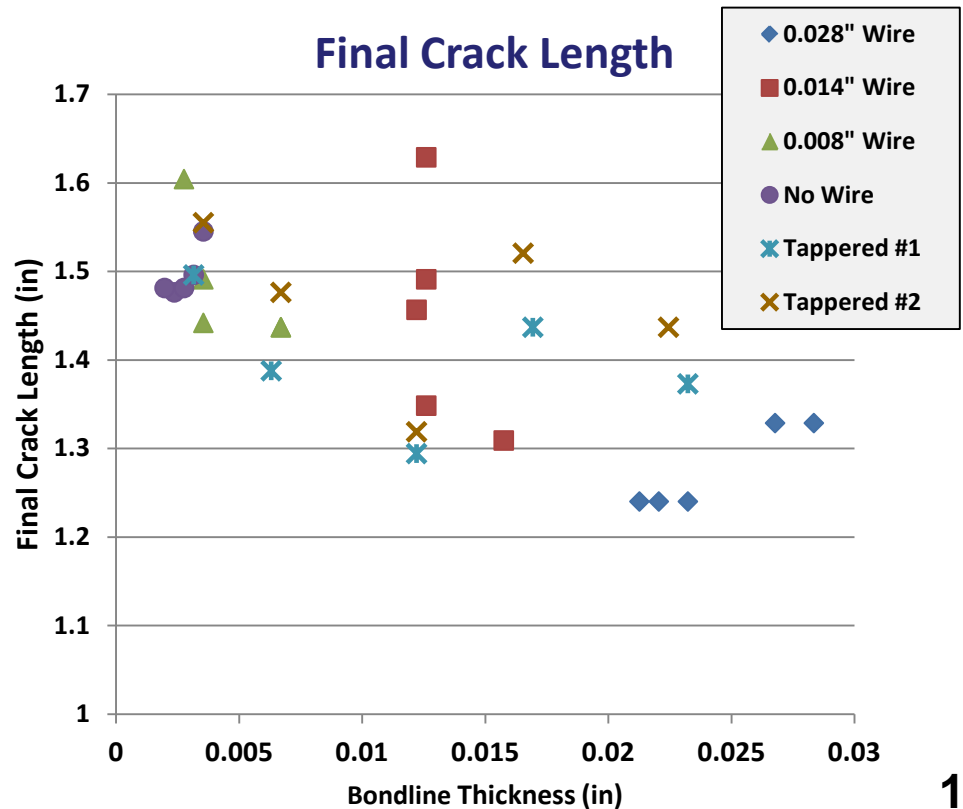

BONDLINE THICKNESS EFFECT: Failure Mode

Increasing bondline thickness increases percent cohesion failure

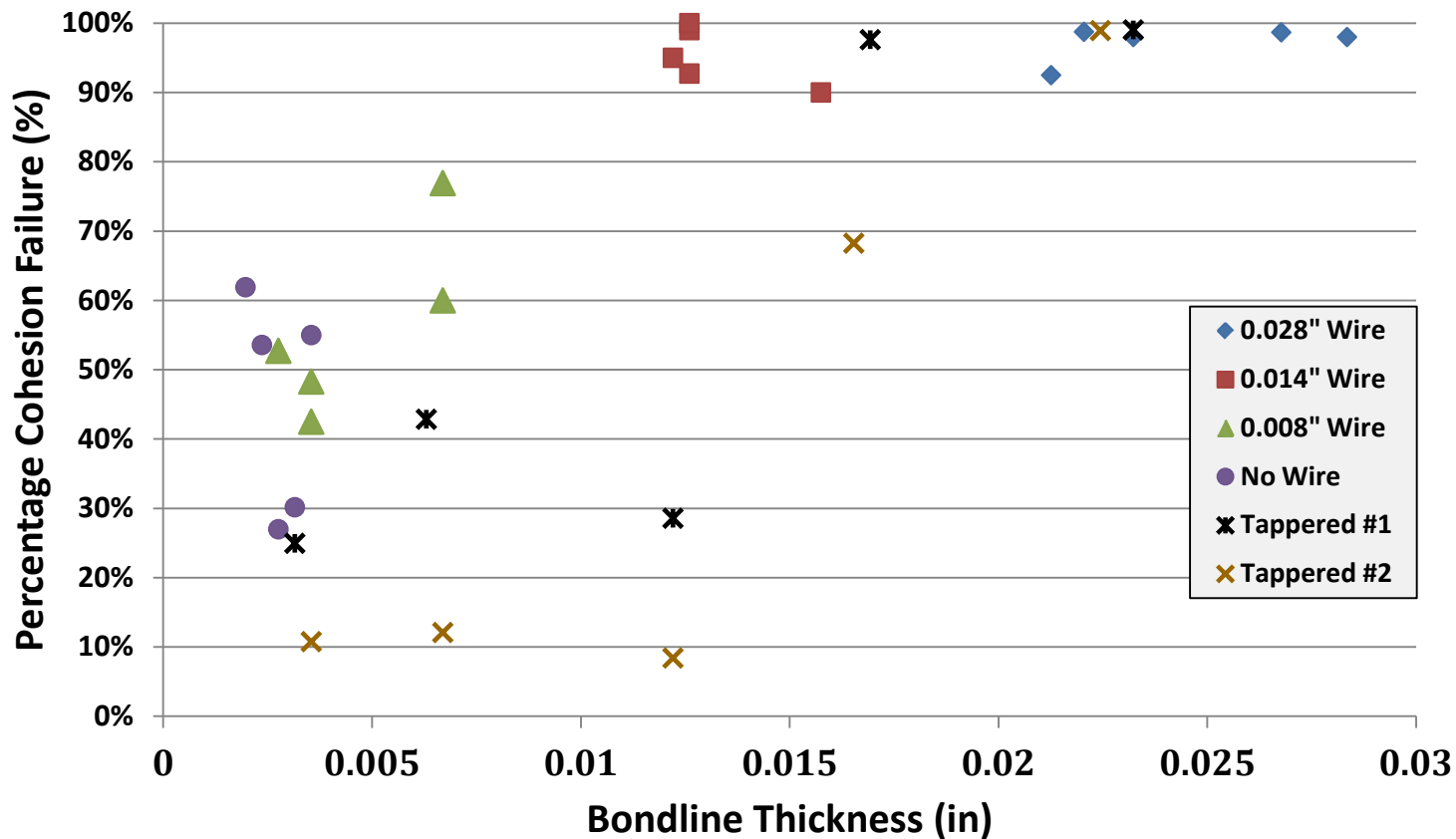

BONDLINE THICKNESS EFFECTS: Summary of Results

- **Increasing bondline thickness decreases:**
 - Initial crack length
 - Final crack length
 - Environmental crack growth
 - Adhesion failure / interfacial failure
- **Significant effect on acceptance criteria?**
 - Environmental crack growth not greatly affected
 - Failure mode affected significantly

Uniformity of bondline thickness is important!

Inform

Report?

Suggest

Require?

AREA OF ADDITIONAL INVESTIGATION: Method of Wedge Insertion

- **Wedge Insertion Rate: “Tappers” vs. “Thumpers”**

- “Tappers” (Pressed)

- Use of drill press (0.2 in/sec)

- “Thumpers” (Hammered)

- Single strike

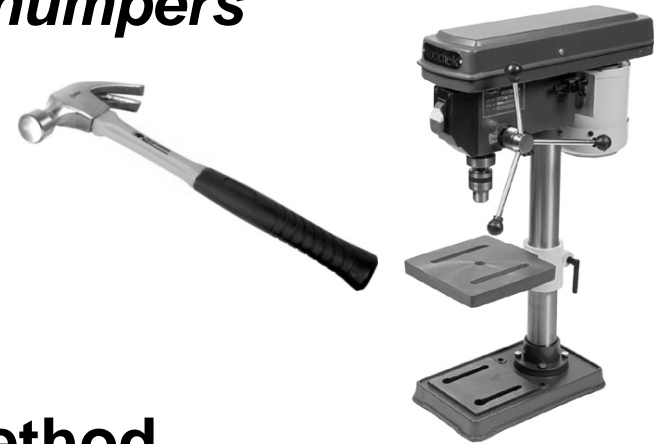

- Investigate effect of wedge insertion method on initial crack length and crack growth after environmental exposure

- Three surface preparations investigated:

- Ideal: PAA & prime

- “Weak”: PAA w/o prime, grit blast & prime

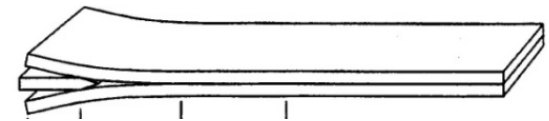

EFFECTS OF WEDGE INSERTION METHOD:

Crack Growth During 1 Week at 50 °C 100% Relative Humidity

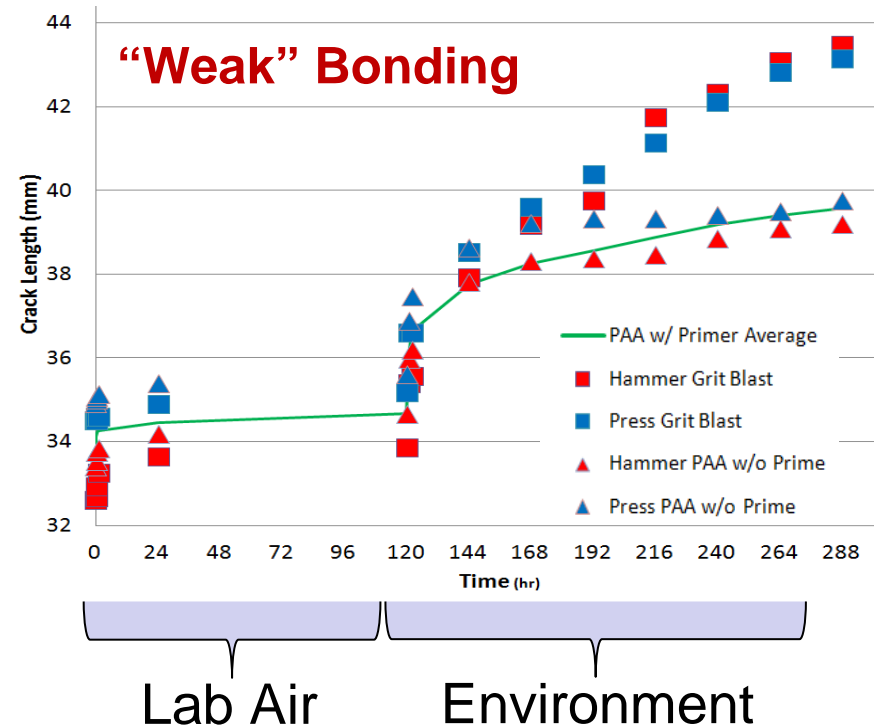
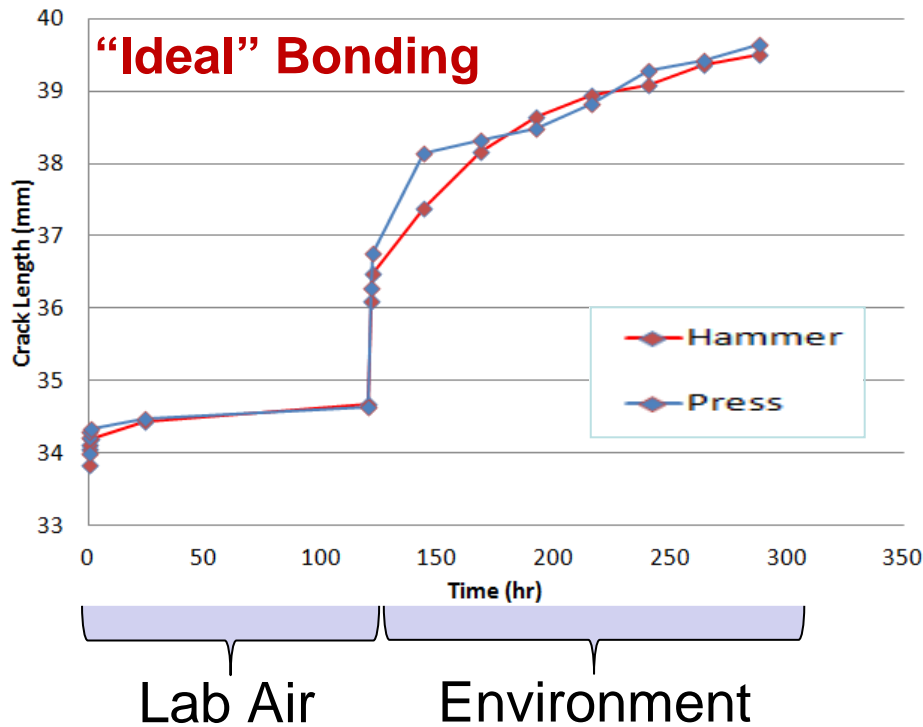

- Difference not statistically significant for “ideal” bonding
- Statistically significant differences for “weak” bonding

EFFECTS OF WEDGE INSERTION METHOD:

Summary of Findings

- **No significant effects with “ideal bonding”**
 - Initial Crack Length
 - Growth Before Environmental Exposure
 - Growth During Environmental Exposure
- **Minimal effects for “weak bonding”**
 - Initial Crack Length
 - Growth Before Environmental Exposure
 - Growth During Environmental Exposure



Inform

Report?

Suggest

~~*Require*~~

EFFECTS OF SPECIMEN ORIENTATION

- Investigate effect of specimen orientation during environmental exposure
 - Three surface preparations:
 - “Ideal”: PAA & prime
 - “Weak”: PAA w/o prime, grit blast & prime
- No statistically significant effect to date for any of the surface preparations with AF-163-2K adhesive

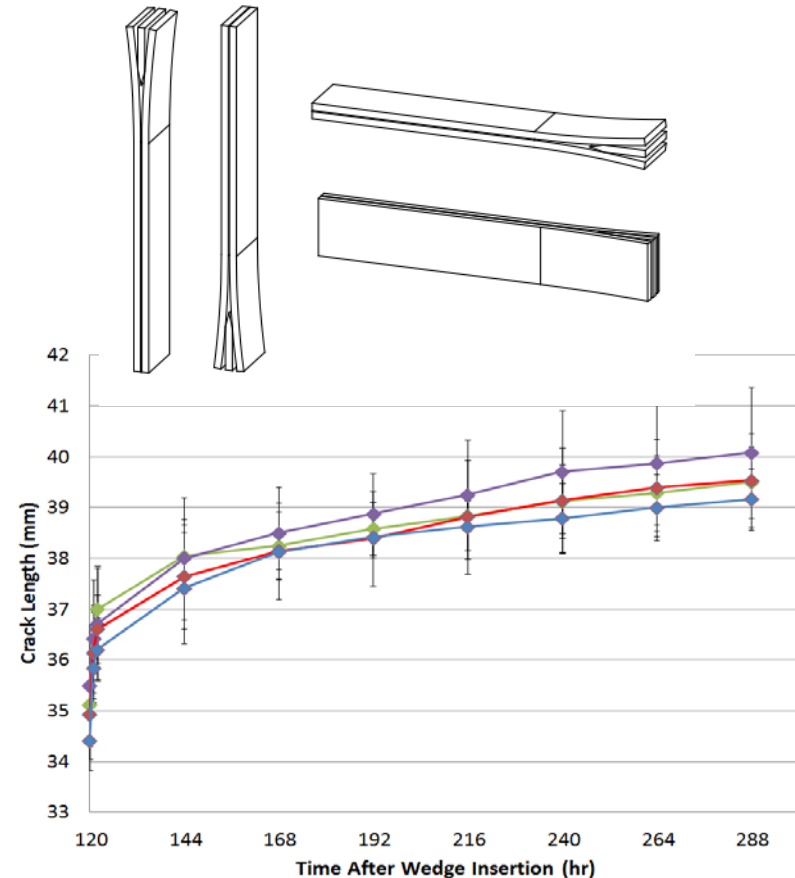

Inform

Report?

Suggest

Require?

PROPOSED CHANGE TO STANDARD: Specimen Orientation During Testing

Current:

Expose the wedged specimens to the environment as required by the appropriate specification, the environments suggested in 8.1, or the environment dictated by actual expected service conditions.

Proposed:

Expose the wedged specimens to the environment as required by the appropriate specification, the environments suggested in 8.1, or the environment dictated by actual expected service conditions. **Position the specimens in the environment in such a way that the crack tip is not exposed to pooling moisture. Two possible orientations are: vertical, with the wedge positioned on the bottom of the specimen, or horizontally with the specimen positioned on one of the finished edges. In the case of the second orientation, care should be taken that the specimen is placed on a rack so the moisture pooling on the bottom surface of the chamber does not effect crack growth.**

REVISION OF WEDGE TEST METHOD: Guidance on Selection Of Test Environment

- **Humidity**

- ASTM D3762
 - Condensing humidity
- TTCP AG13 suggests
 - 95% RH noncondensing

➔ **What role does humidity play?**

- **Temperature**

- 50°C, 60°C, or 70°C

➔ **What role does temperature play?**

- **Duration**

- Hour, day, week, month, or year

➔ **What role does duration play?**

TABLE 1 Standard Test Environments

Test Environment Number	Temperature, °C (°F) ^A	Moisture Conditions % Relative Humidity ^B
1	23 (73.4)	immersed in distilled or deionized water
2	23 (73.4)	50
3	23 (73.4)	15
4	35 (95)	90
5	35 (95)	100
6	50 (122)	90
7	50 (122)	100
8	60 (140)	100
9	71 (160)	100
10	35 (95)	5 % salt fog
11	ambient (outdoors)	ambient (outdoors)
12	other (specify)	other, including aqueous solutions or nonaqueous liquids (specify)

^AThe tolerance for test temperature shall be $\pm 1^{\circ}\text{C}$ or 1.8°F for environments 1 to 10.

^BThe moisture condition may be provided by controlling the relative humidity of a box, room, or other chamber by any convenient means.

REVISION OF WEDGE TEST METHOD: Acceptance Criterion

- **Current example acceptance criterion:**
 - “Typically good durability surface preparation is evidenced by no individual specimen having a crack extension, Δa , exceeding 19 mm (0.75 in.) with the average of all specimens not over 6.3 mm (0.25 in.), when placed in 50°C (122°F) condensing humidity for 1 h.”
- **Crack Extension**
 - Mentioned but not restrictive enough
 - ➔ **What amount/range of growth is acceptable?**
- **Failure Mode**
 - *Not mentioned!*
 - Strong indicator of a durable bond
 - ➔ **What level (percentage) of cohesion failure acceptable?**

PROPOSED CHANGES TO SECTION 9: Failure Mode Measurement

Current:

9.10 At the conclusion of the test, forcibly open the specimen and note the failure mode of the test section.

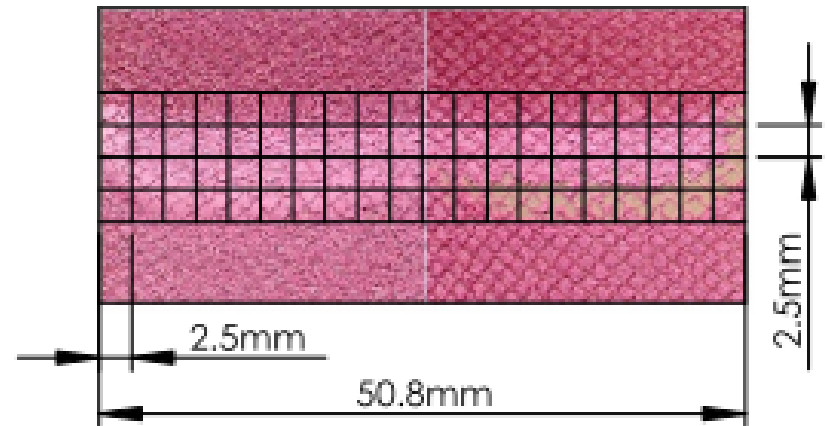

Proposed:

9.10 At the conclusion of the test, forcibly open the specimen and **note approximate** the failure mode of the test section. **Measurements should be reported as percentage adhesion failure or percentage cohesion failure of the fracture surface produced during environmental exposure. The interface at which the failure occurred should also be noted. Measurement can be accomplished using a grid as shown below. The bottom of the rectangular area is made tangent to the curved crack front while the top of the rectangular area is set where the curved crack front reaches the edges of the specimen. The number of squares that make up the test section is estimated. The number of partial and full squares exhibiting adhesion failure is totaled. The percentage adhesion failure is then determined by dividing the number of grid squares containing adhesion failure by the total number of grid squares.**

CURRENT FOCUS:

Use of Different Types of Adhesives

- Perform wedge testing with a second adhesive: FM 300 film adhesive
- Investigate differences between *low toughness* (high strength) and *high toughness* adhesives
 - Different initial crack lengths
 - Differences in importance of specimen preparation and testing parameters
- Investigate variable thickness wedges to produce similar initial crack lengths

CURRENT FOCUS:

Development of a Wedge Test For Adhesively Bonded Composite Laminates

Complexities associated with a composite wedge test include:

- Variable flexural stiffness of composite adherends
 - Must be within a specific range
 - OR**
 - Must tailor wedge thickness for specific composite adherends
- Fiber orientation adjacent to bonded interface

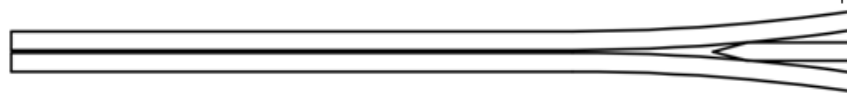

The need for a bonded composites durability test is just as great as it was for metal bonding 20 years ago.”

- John Hart-Smith

International Journal of Adhesion and Adhesives, 1999

DEVELOPMENT OF A COMPOSITE WEDGE TEST: Initial Investigation

- Test sensitivity to thickness and flexural stiffness of composite adherends
 - IM7/8552 Carbon/epoxy
 - Unidirectional and quasi-isotropic laminates
 - Two adherend thicknesses investigated
 - Match thickness of aluminum
 - Match EI of aluminum
 - Surface preparation following “best practices”
 - AF163-2K and FM300 adhesives
- Expected Results:
 - Difference in crack growth based on thickness (EI)
 - Similar % G_{Ic} reductions independent of thickness

CURRENT STATUS

- **Draft of revised standard for metal wedge test (ASTM 3762) underway**
- **Further wedge testing underway to investigate other adhesives**
- **Special presentation on expected changes to ASTM 3762 to ASTM Committee D14 (Adhesives) next week in Indianapolis**
- **Development of composite wedge test underway**

SUMMARY

Benefits to Aviation

- Improved adhesive bond durability test method for metals
- New adhesive bond durability test method for composites
- Method for assessing the durability of adhesively bonded aircraft structures
- Dissemination of research results through FAA technical reports and conference/journal publications

